

---

**U.S. ARMY MEDICAL DEPARTMENT CENTER AND SCHOOL  
FORT SAM HOUSTON, TEXAS 78234-6100**

---



# **IMMUNIZATIONS AND ENVIRONMENTAL INJURIES**

**SUBCOURSE MD0587    EDITION 200**

## **DEVELOPMENT**

This subcourse is approved for resident and correspondence course instruction. It reflects the current thought of the Academy of Health Sciences and conforms to printed Department of the Army doctrine as closely as currently possible. Development and progress render such doctrine continuously subject to change.

## **ADMINISTRATION**

For comments or questions regarding enrollment, student records, or shipments, contact the Nonresident Instruction Section at DSN 471-5877, commercial (210) 221-5877, toll-free 1-800-344-2380; fax: 210-221-4012 or DSN 471-4012, e-mail [accp@amedd.army.mil](mailto:accp@amedd.army.mil), or write to:

COMMANDER  
AMEDDC&S  
ATTN MCCS HSN  
2105 11TH STREET SUITE 4192  
FORT SAM HOUSTON TX 78234-5064

Approved students whose enrollments remain in good standing may apply to the Nonresident Instruction Section for subsequent courses by telephone, letter, or e-mail.

Be sure your social security number is on all correspondence sent to the Academy of Health Sciences.

## **CLARIFICATION OF TRAINING LITERATURE TERMINOLOGY**

When used in this publication, words such as "he," "him," "his," and "men" are intended to include both the masculine and feminine genders, unless specifically stated otherwise or when obvious in context.

## **USE OF PROPRIETARY NAMES**

The initial letters of the names of some products are capitalized in this subcourse. Such names are proprietary names, that is, brand names or trademarks. Proprietary names have been used in this subcourse only to make it a more effective learning aid. The use of any name, proprietary or otherwise, should not be interpreted as an endorsement, deprecation, or criticism of a product; nor should such use be considered to interpret the validity of proprietary rights in a name, whether it is registered or not.

## TABLE OF CONTENTS

<u>Lesson</u>		<u>Paragraphs</u>
	INTRODUCTION	
1	IMMUNIZATIONS/DISEASE REPORTING	
	Section I. Purposes of Immunization/Personnel Eligible for the Army Immunization Program .....	1-1--1-3
	Section II. Basic References Governing the Army Immunization Program.....	1-4--1-6
	Section III. Exemptions and Waivers from Immunization.....	1-7--1-9
	Section IV. Types of Immunity and Types of Immunizing Agents .....	1-10--1-12
	Section V. Reactions and Side Effects to Immunizations.....	1-13--1-16
	Section VI. Precautions to Use When Handling and Storing Immunizing Agents .....	1-17--1-19
	Section VII. Immunizations Required for Foreign Travel.....	1-20--1-22
	Section VIII. Forms Used for Recording Immunizations.....	1-23--1-29
	Section IX. Reportable Communicable Diseases.....	1-30--1-32
	Exercises	
2	IONIZATION, MICROWAVE, AND LASER INJURIES	
	Section I. Ionizing and Nonionizing Radiation .....	2-1--2-6
	Section II. Microwave Radiation .....	2-7--2-11
	Section III. Laser Radiation .....	2-12--2-19
	Exercises	
3	DROWNING AND NEAR DROWNING	
	Section I. General Considerations of Drowning and Near Drowning.....	3-1--3-6
	Section II. On-the-Scene Treatment/Management of the Drowning/Near Drowning Victim .....	3-7--3-8
	Section III. Hospital Treatment/Management of the Near Drowning Victim.....	3-9--3-14
	Exercises	

## TABLE OF CONTENTS

<u>Lesson</u>		<u>Paragraphs</u>
4	HEAT INJURIES	
	Section I. Characteristics/General Findings of Heat Injuries.....	4-1--4-3
	Section II. Mechanisms for the Regulation of Temperature in the Human Body. ....	4-4--4-8
	Section III. Heat Transference Mechanisms .....	4-9--4-14
	Section IV. Factors Affecting Heat Injuries.....	4-15--4-16
	Section V. Heat Cramps.....	4-17--4-19
	Section VI. Heat Exhaustion .....	4-20--4-22
	Section VII. Heatstroke .....	4-23--4-26
	Section VIII. Prevention of Heat Injuries.....	4-27--4-29
	Exercises	
5	COLD INJURIES	
	Section I. Characteristics/General Findings of Cold Injuries .....	5-1--5-4
	Section II. Nonfreezing Cold Injuries .....	5-5--5-6
	Section III. Freezing Cold Injury: Frostbite.....	5-7--5-10
	Section IV. Hypothermia .....	5-11--5-14
	Section V. Sensitization to Cold Injuries.....	5-15--5-16
	Exercises	

**CORRESPONDENCE COURSE OF  
THE U.S. ARMY MEDICAL DEPARTMENT CENTER AND SCHOOL**

**SUBCOURSE MD0587**

**IMMUNIZATIONS AND ENVIRONMENTAL INJURIES**

**INTRODUCTION**

In this subcourse, you will study immunizations and environmental injuries. Environmental injuries include radiation injuries, drowning and near drowning, heat injuries, and cold injuries. Information on immunizations and these environmental injuries are important to medical MOSs. Do your best to achieve the objectives of this subcourse. As a result, you will be better able to perform your job.

**Subcourse Components:**

The subcourse instructional material consists of seven lessons as follows:

- Lesson 1, Immunizations/Disease Reporting
- Lesson 2, Ionization, Microwave, and Laser Injuries.
- Lesson 3, Drowning and Near Drowning.
- Lesson 4, Heat Injuries.
- Lesson 5, Cold Injuries.

Here are some suggestions that may be helpful to you in completing this subcourse:

- Read and study each lesson carefully.
- Complete the subcourse lesson by lesson. After completing each lesson, work the exercises at the end of the lesson, marking your answers in this booklet.
- After completing each set of lesson exercises, compare your answers with those on the solution sheet that follows the exercises. If you have answered an exercise incorrectly, check the reference cited after the answer on the solution sheet to determine why your response was not the correct one.

**Credit Awarded:**

Upon successful completion of the examination for this subcourse, you will be awarded 8 credit hours.

To receive credit hours, you must be officially enrolled and complete an examination furnished by the Nonresident Instruction Branch at Fort Sam Houston, Texas.

You can enroll by going to the web site <http://atrrs.army.mil> and enrolling under "Self Development" (School Code 555).

A listing of correspondence courses and subcourses available through the Nonresident Instruction Section is found in Chapter 4 of DA Pamphlet 350-59, Army Correspondence Course Program Catalog. The DA PAM is available at the following website: <http://www.usapa.army.mil/pdffiles/p350-59.pdf>.

## **LESSON ASSIGNMENT**

### **LESSON 1**

Immunizations/Disease Reporting.

### **LESSON ASSIGNMENT**

Paragraphs 1-1 through 1-32.

### **LESSON OBJECTIVES**

After completing this lesson, you should be able to:

- 1-1. Identify the purposes of immunization and personnel eligible for the Army Immunization Program.
- 1-2. Identify the basic references which govern the Army Immunization Program.
- 1-3. Identify reasons for which exemptions and waivers from immunization may be given.
- 1-4. Identify types of immunity and their characteristics.
- 1-5. Identify types of immunizing agents and examples of each.
- 1-6. Identify reactions and side effects to immunizations.
- 1-7. Identify the precautions that should be used when handling and storing immunizing agents.
- 1-8. Identify the immunizations required for foreign travel.
- 1-9. Identify the forms used for recording immunizations.
- 1-10. Identify the reportable communicable diseases.

### **SUGGESTION**

After completing the assignment, complete the exercises at the end of this lesson. These exercises will help you to achieve the lesson objectives.

## LESSON 1

### IMMUNIZATIONS/DISEASE REPORTING

#### Section I. PURPOSES OF IMMUNIZATION/PERSONNEL ELIGIBLE FOR THE ARMY IMMUNIZATION PROGRAM

##### 1-1. INTRODUCTION

The immunization procedures for the United States armed forces are regularly evaluated and updated. Requirements are precisely related to the geographic area of military duty.

##### 1-2. PURPOSES OF IMMUNIZATION

a. A person can become immune to some diseases naturally by having the disease. However, if a person wants to acquire a certain kind of immunity at a particular time, it is difficult to predict whether the natural process will occur, when it will occur, or whether the infection will cause a severe or fatal disease. It is often desirable to develop immunity safely, with certainty, at certain times, and in certain people.

b. It is desirable for members of the armed forces to have immunizations to conserve their fighting strength by preventing personnel from having diseases which might interfere with the accomplishment of the military mission. Historically, more soldiers have died from diseases which today can be prevented than have died from enemy weapons. Immunizations assure that military units can perform their mission anywhere in the world without delay or detention in travel and without the danger of disease.

##### 1-3. CATEGORIES OF PERSONS ELIGIBLE FOR IMMUNIZATIONS UNDER THE ARMY IMMUNIZATION PROGRAM

The following categories of personnel are eligible for immunizations under the Army immunization program.

a. **Active Duty Personnel.** All personnel entering on active duty for periods in excess of 30 days will receive required routine immunizations. The term "basic trainees" includes all persons without prior service. Immunizations and reimmunizations will be given as soon as possible after arrival at a training or mobilization center or, in the case of persons not so assigned, at the first and subsequent duty stations.

b. **Alert Forces.** These forces are defined as members of units and individuals who have been designated to be in a state of readiness for immediate deployment outside the continental United States or who are to be in such a state of readiness within 30 days or less of notification.



c. **Reserve Component Personnel.** Members of the Army Reserve including ROTC students who are ordered or called to active duty for training within Area I for a period of 30 days or less will be immunized as outlined for Reserve Component Personnel. Army National Guard (ARNG) personnel when called or ordered to active duty or active duty for training under Title 32, U.S. Code Section 502, 503, 504, 505, and Title 10, U.S. Code within Area I or Area II for a period of 30 days or less, will be immunized as outlined for Reserve Component personnel. These immunizations are to be received prior to departing their homes or educational institutions for duty. Entry on such duty will not be deferred provided that the first dose of each required basic series has been administered. Reimmunizations as required will be given prior to such duty.

d. **Military Dependents.** Military dependents remaining in or traveling in Area I are eligible for immunizations. Those traveling to or living outside Area I are also eligible for immunizations. Infants three months of age or older are required to have begun immunizations prior to travel outside Area I.

NOTE: Administration of any live virus vaccines, except oral poliovirus vaccine is considered to be medically contraindicated during pregnancy. A temporary waiver should be granted in this situation and the individual should be advised of the possibility of detention or quarantine while traveling outside Area I.

e. **Federal Civilian Employees and Dependents.** Federal civilian employees and their dependents who travel from or are residing outside the United States or Canada under the sponsorship of the Armed Forces will receive immunizations and reimmunizations in accordance with current requirements and appropriate tables as for nonmilitary personnel. These immunizations will be administered at military activities without charge upon presentation of official orders or authorization.

(1) Federal civilian employees of the Armed Forces who are exposed to risk of disease such as tetanus, smallpox, or other infectious diseases associated with their occupation or service with the Armed Forces will be immunized with an appropriate vaccine upon the recommendation of the staff medical officer. These immunizations will be administered at military activities without charge to the employee.

(2) The installation or activity commander, upon the recommendation of the senior medical officer, may provide immunizations against diseases which may be a significant cause of lost man-hours of work. Such immunizations will be voluntary and will be administered at military activities without charge to the employee.

f. **Foreign Nationals.** Foreign nationals who are coming to the United States, its territories, commonwealths, or possessions under Armed Forces' sponsorship will receive those immunizations required for entry into the United States from that country. When returning to their homelands, foreign nationals will receive immunizations required by the World Health Organization (WHO), International Health Regulations, or their home countries. These immunizations will be administered at military activities without charge, upon presentation of official orders or authorization.

g. **Others.** All other personnel who travel from or are residing outside the United States and Canada under Armed Forces' auspices will receive immunizations and reimmunizations in accordance with the requirements for military dependents. The overseas commander, upon the recommendation of the senior medical officer, may provide immunizations against diseases which may be a significant cause of lost man-hours of work or are judged a potential hazard to the health of the command. Such immunizations will be administered at military activities without charge to the employee.

## **Section II. BASIC REFERENCES GOVERNING THE ARMY IMMUNIZATION PROGRAM**

### **1-4. INTRODUCTION**

Immunization requirements and guidelines change at a very rapid pace as new scientific information is gathered. It is essential that an active effort be made to keep current guidelines on hand and stay up-to-date.

### **1-5. PRIMARY SOURCES OF INFORMATION**

The primary sources of information about Army immunizations are found in these documents: AR 40-562; the World Health Organization's Vaccination Certificate Requirements for International Travel; Morbidity and Mortality Weekly Report (MMWR); TB MED 114, Immunizations; and Report of the Committee on Infectious Disease, "Red Book."

### **1-6. MILITARY IMMUNIZATION PRACTICES**

Military immunization practices are reviewed and established by the Armed Forces Epidemiology Board (AFEB). The Advisory Committee on Immunization Practices recommends federal policies. Its recommendations are published periodically in the MMWR. For urgent inquiries, contact the Center for Disease Control, Atlanta, Georgia. If you have questions concerning immunizations administered by the Army, consult AR 40-564, Immunizations, or TB MED 114, Immunizations.

## **Section III. EXEMPTIONS AND WAIVERS FROM IMMUNIZATION**

### **1-7. INTRODUCTION**

Although immunizations are required for military personnel, it is possible to be exempt from some immunizations or to have permanent or temporary waiver of certain immunizations. General information about immunizations must be noted as follows.

a. **Precautions Before Giving Immunizations.** Before administering any immunizing agent, make provisions for the immediate first aid and medical care of a systemic (anaphylactic) reaction which a person might have. A military or civilian member of the medical department service (preferably an allergist) who is trained and qualified in emergency resuscitative techniques must be present. There must be an emergency tray on hand containing materials for immediate treatment of systemic and other serious reactions. Included in these materials must be a tourniquet and a syringe containing a 1:1,000 aqueous solution of epinephrine.

b. **Army Aviators and Aircrew Members.** Army aviators and aircrew members are restricted from flying for a minimum of 12 hours (24 hours if not detrimental to the mission) after receiving any immunization with the exception of oral poliomyelitis and smallpox vaccinations.

## **1-8. EXEMPTIONS**

Exemptions, permanent or temporary, may be given for medical reasons by the surgeon (staff medical officer) or the commanding officer of a medical treatment facility. It is important to note that travelers not in compliance with International Health Regulations may be subjected to isolation, surveillance, detention, or alternately denied entry to the country in question.

a. Individuals with a history of high sensitivity (such as severe systemic reactions or anaphylaxis to eating eggs) should be exempt from immunizing agents cultivated in eggs. Immunizing agents cultivated in eggs include those for influenza, yellow fever, measles, mumps, and rubella. Allergists should arrange for skin testing with dilutions of egg extract and vaccine product, plus positive and negative controls, under conditions with adequate precautions. Record severe individual reactions or significant proven allergy in the individual's immunization record. When soldiers must be immunized for a military mission, contact a board-certified allergist to make up the schedule for specific immunizations.

b. Army personnel on active duty who have a permanent medical exemption for immunization against yellow fever have a permanent assignment limitation and will not be assigned to areas endemic with yellow fever.

## **1-9. WAIVERS**

There are two kinds of waivers: permanent and temporary.

a. **Permanent.** Permanent waivers may be given for administrative reasons, usually religious beliefs. Some individuals have legitimate religious objection to immunization. Permanent waivers are subject to being revoked when the military mission accomplishment is in danger of being compromised. Persons with permanent waivers will not be assigned to areas where smallpox and yellow fever are endemic. Those are the only assignment limitations which apply to the permanent waiver. The Surgeon General of the Army has the power to grant this waiver.

b. **Temporary.** Temporary waivers of military immunization requirements, except smallpox and yellow fever, may be granted to personnel traveling under Army sponsorship to areas outside the United States and Canada for short tours under conditions which make exposure unlikely. Senior command surgeons have the authority to grant these waivers. A temporary waiver from any immunization of live virus, except oral poliomyelitis, can be granted to a pregnant woman. Administration of any live virus during pregnancy is considered to be contraindicated. The individual should be informed that without required immunizations, she could be detained or quarantined while traveling. Oral poliomyelitis can be administered during pregnancy because the weakened polio viruses rarely pass through the membrane of the intestinal tract.

#### **Section IV. TYPES OF IMMUNITY AND TYPES OF IMMUNIZING AGENTS**

##### **1-10. INTRODUCTION**

a. Become familiar with these words and their meanings.

(1) Antigen. A foreign substance that can stimulate the body to produce antibodies.

(2) Antibody. A substance produced by the body in response to an antigen; this substance is antagonistic to that specific antigen.

(3) Immunity. A condition in which a body is not susceptible to a specific disease.

(4) Vaccine. A preparation of dead or weakened disease organisms used as an antigen in stimulating the body to produce antibodies against a specific disease.

(5) Toxoid. A toxin which has been changed and weakened by one of the following: aging; a chemical process; cold; or heat. This substance will produce antibodies, but the toxoid itself is not harmful to humans.

(6) Immune globulin. The part of human blood containing specific antibodies used to produce a short term passive immunity.

b. There are several types of immunity. Initially, a distinction can be made between immunity acquired naturally and immunity acquired artificially.

### **1-11. ACTIVE IMMUNITY**

a. Immunity acquired naturally is called active immunity. An individual can have the disease, recover, and become permanently immune. Measles, chickenpox, whooping cough, scarlet fever, typhoid fever, Rocky Mountain spotted fever, and diphtheria are examples of such diseases. The person has chickenpox, recovers, and has a permanent immunity to chickenpox. There are other diseases which an individual can have and recover from but not develop a lasting immunity. The group of infections called "the common cold," influenza, gonorrhoea, septic sore throat, and some types of pneumonia are examples. A person can have a cold, recover, and get another cold.

b. When an individual has a disease, antibodies form within the body in response to the stimulation of natural infection or of infectious agents. The antibodies develop slowly, usually after about 10 to 14 days. The length of time the immunity lasts varies depending on the disease.

### **1-12. ARTIFICIAL IMMUNITY**

It is not always convenient or desirable for an individual to have a disease in order to become immune to that disease. Scientists, therefore, have developed artificial processes, such as vaccination, that simulate nature but which are adapted to meet practical requirements and are under human control. Two major types are active artificial immunity and passive artificial immunity.

a. **Active Artificial Immunity.** There are several ways of achieving this immunity: injection of living, attenuated, or harmless organisms; injection of dead organisms; and injection of bacterial exotoxins.

(1) Injection of living attenuated (weakened) or harmless organisms. This type of immunity can be acquired by artificially imitating nature's method of mild infection, thus producing immunity. Smallpox, polio, rubella, measles, mumps, adenovirus, and yellow fever are examples of diseases in which an active artificial immunizing agent is used.

(a) Smallpox. The virus vaccinia, which causes cowpox in cows, when transmitted to humans in a vaccination, causes a mild condition at the site of the vaccination. This is sufficient to give an individual protection from smallpox for a period of from one to ten years, depending on the person and the environmental conditions.

1 The vaccination is performed on the arm over the deltoid muscle. Clean the site gently. Energetic cleansing may create abrasions which may become infected forming "satellite lesions." Apply antiseptics such as ether or acetone (not alcohol) and allow the site to dry thoroughly. Failure to allow the antiseptic to dry may cause the vaccine to be inactivated.

2 To vaccinate correctly, use a bifurcated needle. (A single needle may be used by doubling the punctures.) Dip the needle in the vaccine and touch the skin leaving a droplet. Hold the needle perpendicular to the site and move the needle point through the droplet in a motion perpendicular to the skin. Give primary (first) vaccinations by three firm pressures within a 1/8th of an inch area. Revaccinations five years later consist of 15 firm pressures with a bifurcated needle. With a dry, sterile gauze or cotton-tip applicator, dab the remaining vaccine off the arm. A properly performed vaccination should not bleed freely. Do not apply a dressing unless a weeping lesion appears and, even then, apply the dressing only to protect the clothing. The patient should be so advised.

3 About the third day after vaccination, a papule appears at the vaccination site. The fifth or sixth day this papule becomes a vesicle (small blister). Erythema (redness of the skin) and induration (a spot which is abnormally hard) follow and start to subside about the tenth day, followed by a crust formation which comes off after about 21 days. The primary reaction may be accompanied by lymphadenopathy (lymph node enlargement), fever, and malaise (a general feeling of bodily discomfort).

4 The vaccination is examined following six to eight days. Any reaction that shows a pustule, vesicle, or area of definite redness or induration, regardless of its form, is a MAJOR REACTION. All other responses are termed EQUIVOCAL REACTIONS. All personnel exhibiting equivocal reactions should be immediately vaccinated again using a more vigorous technique and another vaccine lot/batch. Examination of the second vaccination is not necessary and requires no further attempts whether a major reaction or an equivocal reaction occurs.

5 Vaccination should not be given to patients with eczematous skin or atopic dermatitis. Patients should be warned of the possible spread by contact to persons with these disorders. Patients should also be warned to stay out of swimming pools because of the danger of contaminating the water in such pools. Vaccinia virus is an agent used for immunization. This agent can be transferred from one person to another if the vaccinated person is in close personal contact with other people (for example, someone touches the site of vaccination and then touches an area where the skin is scraped or there is a mucous membrane such as the mouth). The vaccine will form stellite lesions in those areas which are touched. For this reason, troops should be vaccinated early during military training to minimize contact with unprotected civilians.

6 Vaccination should only be carried out on healthy individuals. No country requires a smallpox vaccination for entry at this time. The World Health Organization declared the earth to be completely free of smallpox in May 1980. Revaccinations are done after a five year period. No smallpox vaccinations should be administered unless vaccinia immune globulin is readily available to treat systemic vaccinia.

(b) Polio. Currently, there are two types of preventive measures for polio: inactivated poliovirus vaccine (IPV) and live oral poliovirus vaccine (OPV). The preferred vaccine in the United States is the oral poliovirus vaccine, which consists of a mixture of attenuated or weakened strains of types 1, 2, and 3 poliomyelitis viruses produced in cultures of monkey kidney cells.

1 This vaccine should be kept frozen until used, and then used within seven days after the bottle is entered and not refrozen. An unentered container of vaccine may be used after as many as ten freeze-thaw cycles, provided the temperature does not exceed 8°C (46°F), and that the cumulative thaw time does not exceed 24 hours. If the 24-hour period is exceeded, the vaccine must be used within 30 days.

2 The vaccine is only given by mouth. The vaccine may be added to a sugar cube, simple syrup, or distilled water, or it may be given with a sterile medicine dropper. It should not be given in tap water or a beverage containing free chlorine. Advise all persons not to eat for 30 minutes after swallowing the vaccine.

3 In a few instances, a neurological disease similar to paralytic poliomyelitis has been reported to occur 4 to 30 days after vaccination. Do not give the vaccine during an illness accompanied by a fever (a febrile illness). Although normally live viral vaccines are not given during pregnancy, the polio vaccine can be given during pregnancy.

4 The dose for polio is usually two drops and may come in containers as individual doses or multiple dose vials. Check manufacturer's inserts for the proper number of drops which make up a dose. Immunization is good for life following a series of five doses. All soldiers receive one, two-drop dose upon entry on active duty. Reimmunization is not required. Immunodeficient patients (those with an immune response deficiency) and unimmunized adults may require a series of the Salk-killed poliomyelitis vaccine injection. The subject of decreasing immunity over time is currently being evaluated.

(c) Measles. Live attenuated measles-virus vaccines produce an inapparent or mild infection which is noncommunicable and is followed by immunity for at least ten years. The available evidence indicates that a single inoculation will generally be followed by permanent immunity. There have been rare cases of children having been vaccinated and then actually having measles several years later. Experience with approximately 30 million doses administered in the United States between 1963 and 1968 indicates that the vaccines are safe and highly effective. Measles now occurs predominantly in communities which have failed to immunize their children. Live measles vaccine, 0.5 ml, should be given to all infants and children over 15 months of age if they have not had measles. Vaccination of adults is rarely necessary because nearly all are immune by age 18.

NOTE: Most measles cases are imported from overseas. An American who is traveling overseas and who has no immunity to measles is a potential candidate for actually getting the disease.

(d) Mumps. The use of live attenuated mumps vaccine is not routinely recommended for military personnel but should be limited to use in certain outbreaks of mumps. Under such circumstances, the vaccine should be given to all individuals, including dependents, who have not had mumps.

1 The vaccine may be used at any age from 12 months on. It should not be administered to children less than 12 months because of possible interference with persisting maternal immunity. The mumps vaccine is of particular value to children approaching puberty, in adolescents, and in adults, especially males.

2 The mumps virus, grown in a chick embryo fibroblast tissue culture, is supplied as freeze-dried material and should be stored at 2°C to 8°C. Reconstituted vaccine should be used immediately or within eight hours if held at 2°C through 8°C. Reconstituted vaccine not used within this time limit should be discarded. Vaccination is by one dose of 0.5 ml given subcutaneously. This virus is commonly administered in a mix including measles and rubella (MMR). Do not confuse it with Mumps Skin Test Antigen, which is used for delayed hypersensitivity skin testing.

NOTE: When dependents are receiving measles and mumps vaccinations, delay vaccinating women who have just given birth for one year after that birth. The reason is that maternal antibodies may cause the vaccination to be ineffective since maternal antibodies may destroy the weakened viruses in the vaccine for a period of 1 to 12 months.



(e) Rubella. The live, attenuated rubella virus vaccine appears to be a highly effective immunizing agent and the first suitable method of controlling rubella. Rubella is generally a mild illness, but if the infection is acquired by a woman in the early months of pregnancy, it is a direct hazard to the fetus. Preventing infection of the fetus is the principal objective of rubella control. This can best be achieved by eliminating the transmission of virus among children, children being the major source of infection for susceptible pregnant women. Furthermore, the live, attenuated rubella virus vaccine is safe and protective for children, but the vaccine is not safe for pregnant women because of an undetermined risk of the vaccine virus for the fetus.

**CAUTION:** DO NOT routinely vaccinate adolescent girls and adult women because there is a danger that the vaccine could be inadvertently administered to a pregnant woman who does not yet know that she is pregnant.

1 Rubella vaccination is administered one time with 0.5 ml given subcutaneously or intramuscularly. The vaccine is available alone or in a multiple vaccine, MMR - mumps, measles, rubella.

2 Female recruits will receive measles and rubella vaccines prior to the eighth day of active duty with the exception of those found immune to rubella by serological testing (titer). These will receive measles vaccine only. Any female who suspects pregnancy will be exempted until pregnancy is ruled out.

(f) Adenovirus. This is a vaccine given to military recruits due to their susceptibility to adenovirus illnesses during basic training. Adenoviruses are viruses (found in all parts of the world) that cause disease of the upper respiratory tract and conjunctivae. The viruses are also present in latent infections in normal persons. Adenovirus vaccine tablets (types 4 and 7) are available only to the military and not to the public. One tablet of each type is administered orally within the first seven days after arrival at basic training. The tablets do not need to be refrigerated. Each tablet contains monosodium glutamate (MSG) as a preservative and tartrazine dye.

(g) Yellow fever. Everyone traveling to areas in which yellow fever is endemic must be immunized or reimmunized not less than 12 days or more than ten years prior to arrival at their destination. The 12-day interval does not apply to travelers to the Panama Canal Zone.

1 Vaccination against yellow fever is considered to provide almost absolute immunity lasting at least ten years. The vaccine comes from live, attenuated virus which is reconstituted according to the manufacturer's instructions. The package usually contains diluent (isotonic sodium chloride) that is packed separately and which should not be frozen. The resultant mixture is a 1:10 dilution of the concentrated vaccine. Any vaccine remaining at the end of one hour after reconstitution should be discarded.

2 The vaccination dose for all ages is 0.5 ml given subcutaneously or intramuscularly. Reimmunization is given every 10 years with a dose of 0.5 ml.

(2) Injection of dead (killed) organisms. In this method of producing active artificial immunity, the microorganisms which are to be injected have been killed or inactivated by heat or some chemical disinfectant. Examples of immunizing agents of this type are those used for protection against typhoid, cholera, influenza, plague, and meningococcal.

(a) Typhoid. Typhoid vaccine consists of Salmonella typhi that is killed and dried with acetone to preserve its antigen capabilities. Vaccination consists of a subcutaneous or intramuscular injection of two 0.5 ml doses in the triceps area at an interval of four to eight weeks. Revaccination is 0.5 ml in three years if authorized by higher authority prior to military deployment. Typhoid may be administered more often if indicated by high risk conditions. Revaccination is required only for Alert Forces and in areas of high prevalence. Advise patients to drink water only from approved pure sources. A 50-dose vial of freeze-dried vaccine is available only through military supply channels.

(b) Cholera. For cholera, vaccination is of secondary value to the necessity for sanitary measures to prevent the contamination of food and water. Vaccination alone will not prevent cholera. Advise the person receiving the vaccination to practice preventive measures.

1 These preventive measures are good to observe in an area in which there is cholera. Practice good hygiene habits. Drink only water that has been purified or chlorinated or is otherwise considered safe. Use scrupulous cleanliness when handling or preparing food and store all food at appropriate temperatures. If you are not certain when eating away from home that sanitary practices are observed, select foods that are cooked and served hot. Be sure all milk and dairy products have been boiled or pasteurized.

2 Vaccination is accomplished upon deployment to a country which requires the cholera vaccination for entry. Revaccination is upon the recommendation of the area command surgeon. Injection consists of 0.5 ml of the killed cholera organisms (Vibrio cholerae). Booster injections, if recommended, come at six month intervals and are also 0.5 ml.

(c) Influenza. The composition of influenza vaccine must be changed periodically because of the year to year variation in the strains of influenza A and B viruses isolated from patients around the world and the variety in the immunity of the population. The vaccine is made of virus grown in chick embryos, purified, and inactivated with formalin.

1 Vaccination consists of a dose of aqueous vaccine of 0.5 ml given subcutaneously or intramuscularly. Before giving the vaccination, be sure any individual with a true, severe allergy to chicken or its by-products has been evaluated.

2 All military personnel are immunized against influenza because of their role as essential workers. This annual immunization program is normally started in October. Immunization should be given approximately one month prior to the beginning of the respiratory disease season.

3 The annual influenza vaccination program provides a good time to assess all patients for their total immunization needs: protection from tetanus, diphtheria, hepatitis B, pneumococcal pneumonia, and recent tuberculin skin test.

(d) Plague. The effectiveness of plague vaccine has never been accurately determined, but it is known that immunization reduces the incidence and severity of insect-borne disease, the bubonic form. Basic immunization consists of one intramuscular injection of 1.0 ml followed in three months by an intramuscular injection of 0.2 ml. Vaccination is not a condition for admission to any country. Booster injections, when given, will be 0.2 ml given intramuscularly at six month intervals. These vaccinations are given only on specific authorization from higher headquarters.

1 Plague immunization will be given to Alert Forces before they are deployed to an area where the disease is prevalent. The first dose of 1.0 ml is considered adequate protection to permit travel to a plague area. At no time is the dose of 1.0 ml to be repeated if the individual has already been immunized with plague.

2 Sensitization to the vaccine results in increased reactivity with subsequent doses. For this reason, the dose for booster injections is reduced in volume and only given intramuscularly. Boosters are only given to people residing in areas where plague is prevalent and not more often than every six months. Once a basic series has been given, do not give the series or a booster shot.

(e) Meningococcal. Like adenovirus, the vaccine for this disease is given to military recruits because of their susceptibility to these respiratory illnesses during basic training. The vaccine will be given as directed by the Surgeon General. The vaccine is considered safe and very effective. Meningococcal vaccine for military recruits consists of four strains: A, C, Y, and W-135. Occasionally, a dose of the bivalent (A and C strains only) vaccine may need to be given to a pediatric patient. Dosage for both groups is 0.5 ml once, without the need for a booster.

(3) Injection of bacterial exotoxins. In this method of providing active artificial immunity, no organisms, living or dead, come in contact with the body. The immunizing agent is a substance derived from a toxin for a specific disease. The toxin, called a toxoid, has been heated and combined with formaldehyde. Toxoids are not poisonous and act as specific antigens. After toxoids have been properly purified and packaged under strictly sterile conditions, the toxoids are very safe immunizing agents. Examples of toxoids as the immunizing agent are immunizations for tetanus and diphtheria as well as the combined immunization for diphtheria, tetanus, and pertussis.

(a) Tetanus-diphtheria toxoid. This product contains tetanus toxoid and small amounts of diphtheria toxoid which have been shown to immunize 95 percent of the adults after three doses. The basic series consists of three injections of 0.5 ml. The first dose is followed in four to eight weeks by the second. One year later the third reinforcing dose, a dose that is protective for ten years, is given. Reimmunization is accomplished by injecting 0.1 or 0.5 ml of the tetanus-diphtheria toxoid in ten years or at the time of an injury. If vaccination was more than six years prior to injury, 0.5 ml is given for punctures or lacerations as a precaution. Refer to the recommendations of the Public Health Service Advisory Committee regarding wound management guidelines for more information. The adult tetanus/diphtheria toxoids product (Td) is used for children over six years old. Diphtheria toxoid, tetanus toxoid, pertussis vaccine (DTP) in combination is a pediatric product used for children from two months to six years. This product contains a higher portion of the diphtheria toxoid component plus the pertussis vaccine than the Td product. The product TD (without pertussis vaccine) is also available for children if pertussis vaccine is contraindicated.

(b) Diphtheria toxoid, tetanus toxoid, and pertussis vaccine (DPT). This combination of immunizing agents is a pediatric preparation for immunizing children under seven years old. Immunization is accomplished by administering intramuscular injections of 0.5 ml at 2, 4, 6, and 18 months. Another dose is given between four and six years. Booster injections are given after the age of six years with adult Td and are repeated every ten years. Oral poliomyelitis (trivalent) doses are given at the same time as the first five doses of DPT. The use of pertussis vaccine has generated a great deal of alarm because of an exaggerated fear of neurologic damage to young patients. Pertussis vaccine is associated with a small percentage of serious adverse reactions. Seizures and brain damage have been reported. However, the risk of pertussis disease with its own serious side effects far outweighs the risk of vaccine-associated illness. This has been demonstrated during pertussis outbreaks in England and other countries. There are ways to minimize side effects, such as delaying doses until after fever or seizures have stopped. Details are presented in the 6 April 1984 edition of the Morbidity and Mortality Weekly Report (MMWR).

(c) Anthrax

1 Military indication. The aim is to prevent anthrax infection by any route of exposure due to spores or the bacteria *Bacillus anthracis*. Inhalational anthrax is almost uniformly fatal once symptoms develop.

2 Military and civilian personnel. Administer anthrax vaccine to military personnel and applicable civilians according to DOD or USCG policy for the Anthrax Vaccine Immunization Program and Service-specific implementation plans. Anthrax immunization will be conducted for personnel in geographical areas or in occupational roles designated by the Services, chairman of the Joint Chiefs, or the Office of the Secretary of Defense as being at higher threat for release of anthrax as a weapon.

3 Occupational risk. Administer anthrax vaccine to at-risk veterinary and laboratory workers and others at occupational risk of exposure.

(4) Reimmunization. In most of the processes of active artificial immunization, several injections of the immunizing agents (antigens or immunogens) are used. The body's response to initial contact with most antigens is rather slow, requiring two to ten weeks to reach fully effective quantity of antibodies. Reimmunization is necessary because the antibodies and the immunity of the individual who has been immunized may decline to a very low level as the years pass. The body cells respond much more quickly on reimmunization. For this reason, only a small, single dose of the antigen, the booster dose, is needed to reestablish a high grade immunity.

b. **Passive Artificial Immunity.** Passive immunity is immunity resulting from injections of ready-made antibodies. The person becomes immune by receiving the antibodies passively; the person's tissues play no part in actively producing the antibodies. The need for passive immunity occurs when a person has been exposed to and is in danger of becoming ill with a disease of a very serious nature. There is no time to wait for the person to develop an active immunity, either natural or artificial. The person must have a supply of ready-made antibodies now. Measles immune globulin, human rabies immune globulin (HRIG), and hepatitis immune globulin (HBIG) are examples of passive immunizing agents.

(1) Measles immune globulin. German measles (rubella) is rarely harmful to a woman in childhood. However, if it occurs in a pregnant woman during the first three months of the pregnancy, it often causes severe damage to the fetus. Deformities or defects are particularly likely to occur in the heart, ears, brain, and eyes. Women who are not immune can receive passive immunity during the first three months of pregnancy. Gamma globulin (antibodies) from the blood of immune persons is used. The results are variable.

(2) Human rabies immune globulin (HRIG). HRIG is human anti-rabies gammaglobulin concentrated by cold ethanol fractionation from plasma of hyperimmunized human donors. The rabies neutralizing antibody content is standardized to contain 150 international units (IU) per ml. HRIG is an immunizing agent given after an individual has been exposed to rabies.

(a) Post-exposure regimen. Begin by an immediate, thorough cleansing and flushing with soap or detergent and water of all wounds caused by a bite or scratch of an animal. Do not suture the wound unless it is unavoidable for cosmetic or tissue support reasons. If sutures have been necessary, however, replace them after antiserum has been administered locally. Be sure the new sutures are loose and noninterfering so that the wound is still able to drain and bleed.

(b) For persons previously immunized by the recommended regimen with human diploid cell rabies vaccine (HDCV) or who have previously demonstrated rabies antibodies, administer a dose of 1.0 ml of HDCV on day zero and day three. Do not give rabies immune globulin (RIG).

(c) If the immune status is not known, the full post-exposure regimen may be necessary. If sufficient antibody can be demonstrated from a serum sample, treatment can be discontinued after at least two doses of HDCV have been administered.

(d) Persons not previously immunized will receive rabies immune globulin (RIG), 20 IU per kilogram or body weight, one half infiltrated at the site of the bite (if possible) and the remainder administered intramuscularly.

(e) Anti-rabies serum (ARS) derived from horses was replaced by human RIG, and ARS is now obsolete. In the event that ARS is the only passive immunization agent available (in a third world country, for example), administer or test the dose as for any equine serum product.

(f) Human diploid cell rabies vaccine (HDCV) is an inactivated virus vaccine, prepared from fixed rabies virus grown in human diploid culture. Fewer doses are required to establish protection, and reactions at the site of vaccination are minor. This vaccine can be used as a preventive measure against rabies and can be offered to people in high risk groups--veterinarians, animal handlers, certain lab workers, and persons spending more than thirty days in foreign countries where rabies is a constant threat. (In the last instance, immunization should be given to young children since they might not want to identify a potentially rabid animal.) Also, dogs, cats, foxes, skunks, bats, or any other species at a risk of having rabies should be considered for pre-exposure immunization. Presently, the United States Army regards special forces soldiers in this category and requires them to receive and complete the pre-exposure series. Additionally, HDCV is readily available to anyone considered at risk. The pre-exposure dosage regimen of HDCV is 1.0 ml given intramuscularly on days 0, 7, and 21 or 28. If the quantity of antibodies (titer) falls below 1:5, booster vaccine may be needed. The post-exposure regimen is given in table 1-1.

	Moderate conditions WBGT or WD less than 80 <sup>o</sup> ; hours of work.		Severe conditions, WBGT or WD greater than 80 <sup>o</sup> ; hours of work.		
	Morning	After- noon		Morning	After- noon
First day	1	1	First day	1	1
Second day	1½	1½	Second day	1½	1½
Third day	2	2	Third day	2	2
Fourth day	3	3	Fourth day	2½	2½
Fifth day	Regular duty		Fifth day	3	3
			Sixth day	Regular duty	

Table 1-1. Rabies post-exposure regimen.

## Section V. REACTIONS AND SIDE EFFECTS TO IMMUNIZATIONS

### 1-13. INTRODUCTION

Because of the possibility of adverse reactions, the established dose and schedule recommended for each vaccine should not be exceeded. All medical officers and other personnel concerned with administering immunizations should be impressed with the seriousness of potential reactions and precautions to be taken to prevent these reactions.

### 1-14. ACUTE ANAPHYLACTIC REACTIONS

These reactions usually occur within 30 minutes after injection. Circulatory collapse and respiratory difficulties take place. These difficulties may lead rapidly to death if not treated immediately. Local or systemic subacute allergic reactions may also occur as well as reactions such as serum sickness which includes certain characteristics of both the acute and subacute variety.

### 1-15. DELAYED REACTIONS

After several hours or a few days, some vaccines may produce local reactions (induration, erythema, and tenderness) at the site of the injection. These reactions may be accompanied by systemic reactions consisting of fever, headache, malaise, chills, gastrointestinal upset, and other related symptoms. Symptomatic treatment with antipyretic and analgesic drugs and rest is usually adequate.

a. **Typhoid Vaccine.** Reactions to typhoid vaccine include pain, erythema, induration, and swelling. Fever, myalgia, headache, and malaise may also be manifested. Typhoid vaccine should not be given with other vaccines that may produce similar reactions. This vaccine should also be avoided during febrile illness, intensive physical activity, and during high environmental temperatures.

b. **Influenza Vaccine.** Be sure that people with a true, severe allergy to chicken or its by-products are evaluated before receiving this vaccine. Mild symptoms or reactions in the general population may frequently be controlled with aspirin or acetaminophen.

c. **Plague Vaccine.** About ten percent of the people receiving plague vaccine will experience general malaise, headache, local erythema (skin redness), and induration (an abnormal hard spot), mild lymph node involvement, and fever. Individuals sensitive to the vaccine become more sensitive with subsequent vaccine doses. For this reason, the dose for booster injections is reduced in volume and only given intramuscularly. Additionally, boosters are given only to people living in areas where plague exists and not more often than every six months. Once a basic series has been given, it should not be repeated regardless of the length of time since the completion of the basic series.

## 1-16. REACTIONS/SIDE EFFECTS

Immunizations for these diseases may cause reactions and/or side effects.

a. **Diphtheria.** Reactions are extremely rare. However, using pediatric preparations on adults can cause severe reactions.

b. **Pertussis.** It is fairly common to have these side effects: local induration and tenderness at the injection site; malaise; and mild to moderate fever. In rare instances (usually with DPT), severe reactions can occur such as the following:

- (1) Pronounced fever--105° F.
- (2) Collapse with rapid recovery.
- (3) Screaming episodes.
- (4) Isolated convulsions.
- (5) Encephalopathy--disfunction of the brain to include changes in level of consciousness and focal neurological signs such as quivering of an extremity, convulsions.
- (6) Thrombocytopenic purpura--hemorrhage in the skin.

c. **Tetanus.** Side effects include local induration and tenderness plus a mild fever. An adverse reaction which rarely occurs is urticaria (a vascular reaction of the skin marked by the temporary appearance of smooth, slightly elevated patches (wheals or hives) which are redder or paler than the surrounding skin and often attended by severe itching).



d. **Measles.** Fever, maculopapular rash, and local reaction at the injection site are possible side effects. An adverse reaction occurs usually only after an inactivated vaccination; the person may contract measles several years later. For this situation, it is recommended that revaccination be with live attenuated vaccine.

## **Section VI. PRECAUTIONS TO USE WHEN HANDLING AND STORING IMMUNIZING AGENTS**

### **1-17. INTRODUCTION**

All biologicals obtained in this country for general use in the Armed Forces must conform to the regulations of the Public Health Service regarding such materials. Immunizing agents procured from sources not licensed by the Department of Health and Human Services will meet standards acceptable to the National Institutes of Health or the appropriate Armed Service Investigational Drug Review Board. Expiration periods are based upon comprehensive experience and study of the rate at which specific biologicals lose immunizing potency. Based on the surveillance and assay of storage lots, potency periods (dating) may be curtailed or extended (under very specific limitations) by the Surgeon General.

### **1-18. STORAGE OF BIOLOGICALS**

a. **Yellow Fever.** Yellow fever is a live attenuated virus and comes frozen. It must be stored at below 0° C or below 32° F and must be used within one hour after thawing. (-15 to -18° C and 0 to 5° F is ideal.) Thawing or evidence of thawing during and after shipment renders the shipment unacceptable for use.

b. **Polio Virus Vaccine.** Oral, live poliomyelitis vaccine also comes frozen and, as with yellow fever, vaccine must be stored at below 0° C or below 32° F. Once used, the remainder must be kept in a refrigerator at 2° to 8° C or 35° F to 45° F. The maximum storage time is seven days.

c. **Vaccine Temperature.** All other vaccines should be kept refrigerated and stored at between 2° C to 8° C or 35.6° F to 46.4° F. Never freeze these vaccines. Keep a record on the refrigerator door. Twice a day write the temperature of the refrigerator and the freezer on this record.

d. **Vaccine Change or Possible Change.** Shipments will not be accepted for use if there is a change in the physical appearance or evidence which suggests bacterial contamination or growth. Evidence of alteration or knowledge that during shipment the vaccines were subjected to temperatures varying from those indicated will necessitate withholding the vaccine from issue or use. If there is any doubt regarding the appearance, storage, etc. of any antigen, don't use it. Return it to the appropriate source (supply, pharmacy, etc.) with notations.

e. **Expiration.** Immunizing agents will not be used beyond the stated expiration dates unless authorized in writing by The Surgeon General.

## 1-19. DISPOSAL OF BIOLOGICALS

All live vaccines, containers, syringes, and so forth are infectious waste and a potential hazard. The only safe methods of disposal are burning, boiling, or autoclaving (an autoclave is an apparatus for sterilizing by steam under pressure). Containers of killed vaccines should be discarded in accordance with local standing operating procedure (SOP).

## Section VII. IMMUNIZATIONS REQUIRED FOR FOREIGN TRAVEL

### 1-20. INTRODUCTION

The World Health Organization (WHO) has adopted international health regulations (IHR) to ensure maximum security against the international spread of diseases and, at the same time, ensure a minimum of interference with people traveling throughout the world.

### 1-21. U.S. ARMY IMMUNIZATION REQUIREMENTS FOR FOREIGN TRAVEL

a. **Smallpox.** In 1980, the World Health Organization declared that smallpox had been eradicated on a global basis. There is no evidence of smallpox being transmitted anywhere in the world. Therefore, smallpox is no longer a required vaccination. Previously, for the military, a smallpox vaccination had been required for those going to Benin, Chad, Ojiboati, Lesotho, Mali, Rhodesia, and Democratic Kampuchea. The immunization is valid for five years starting eight days after the first injection.

b. **Cholera.** A few countries require cholera immunization before a person enters the country. The immunization is valid for six months starting six days after the first injection.

c. **Yellow Fever.** It is recommended that persons traveling to all countries currently reporting yellow fever be vaccinated. There are areas of South America, sub-Saharan Africa, and a few African countries where yellow fever is prevalent. The immunization is valid for ten years starting ten days after the injection.

d. **Recommendation.** Be sure immunizations for yellow fever and cholera are current when you are traveling overseas. The dates for those immunizations will be checked.

## **1-22. U.S. ARMY IMMUNIZATION RECOMMENDATIONS FOR FOREIGN TRAVEL**

- a. **Plague.** Immunization for plague is recommended for anyone traveling to Vietnam, Laos, or Cambodia.
- b. **Rabies.** The DEV (duck embryo vaccine) is recommended for residents in areas of high rabies incidence.
- c. **Typhoid.** This vaccine is recommended for persons traveling to areas where the sanitation is poor and for those who live in areas in which outbreaks of typhoid are regular.
- d. **Typhus.** Immunization is considered for high risk occupational groups and for those who travel or live in remote highland areas of Ethiopia, Rwanda, Burundi, Mexico, Ecuador, Bolivia, Peru, and mountain areas of Asia.
- e. **Tuberculosis.** Bacillus Calmette-Guerin (BCG) vaccination is considered for tuberculin-negative children who live or travel extensively in areas where personal contact with tuberculosis is likely.
- f. **Hepatitis.** Immune serum globulin (ISG) immunization is considered for travelers who spend three or more months in tropical areas or developing countries and bypass ordinary tourist routes.

## **Section VIII. FORMS USED FOR RECORDING IMMUNIZATIONS**

### **1-23. INTRODUCTION**

There are two forms normally used to record immunizations: Public Health Service (PHS) 731, International Certificates of Vaccination and Standard Form (SF) 601, Health Record and Immunization Record.

### **1-24. INTERNATIONAL CERTIFICATES OF VACCINATION AS APPROVED BY THE WORLD HEALTH ORGANIZATION (PHS-731)**

PHS Form 731 (the "yellow shot record") will be prepared for every individual receiving immunizations. This form will be prepared for each member of the Armed Forces and for nonmilitary personnel when required. PHS Form 731 serves as the official record of immunizations for international travel and will remain with the individual.

- a. When an individual is traveling, the time limits for the validity of smallpox, yellow fever, and cholera, as shown on the form, will be closely observed. Entries of "other immunizations" should be made in the appropriate spaces.

b. Entries for smallpox, yellow fever, and cholera will be authenticated by the Department of Defense immunization stamp and the actual signature of the medical officer (M.D.) or his designated representative who will sign his name over the physician's stamped, printed, or typed name and facility address. Origin and batch number will also be recorded for yellow fever and smallpox.

c. Entries on PHS Form 731 may be based on:

(1) Immunization administered at the preparing facility.

(2) Transcripts from official records.

(3) Transcripts from written statement of civilian physicians if sufficient information is provided.

### **1-25. STANDARD FORM 601**

Standard Form 601 will be prepared and permanently maintained in the record for each individual for whom an outpatient treatment record is maintained. Individuals preparing the SF 601 and PHS 731 will ensure that appropriate entries are recorded on both forms and that both forms have the same information.

### **1-26. PHS FORM 731 AND SF 601**

a. For both records, written statements from civilian physicians attesting to immunization with approved vaccines giving dates and dosages may be accepted as immunization. Be sure information is transcribed to official records.

b. Booster immunizations for all such completed series will be administered to maintain a common immunologic level.

### **1-27. DESIGNATED REPRESENTATIVE FOR THE MEDICAL OFFICER**

All individuals designated as representatives for the medical officer will be registered nurses, hospital corpsmen/medical technicians, or physician assistants. Such persons will have had special indoctrination in the administration and technical aspects of immunization procedures. Medical officers on the staffs of major commands or commanding officers of medical treatment facilities will compile and maintain a current list of persons authorized to administer immunizations. These records will be available for review and inspection.

### **1-28. SPECIFIC ENTRIES**

Entries for tetanus-diphtheria toxoid will be recorded as Td or TD, depending on the dose. Tetanus toxoid is recorded as Tt, although there are extremely few cases where tetanus toxoid alone would be preferred over a tetanus/diphtheria combination.

## 1-29. MAINTENANCE OF PERSONNEL IN IMMUNE STATUS

Ensuring that all personnel are current in immunizations is a command responsibility. Status immunization for each person will be checked by the unit commander at appropriate intervals.

### Section IX. REPORTABLE COMMUNICABLE DISEASES

## 1-30. INTRODUCTION

It is necessary to report certain communicable diseases. This information aids the commander in maintaining current information on the status of conditions in the command. In that way, appropriate action can be taken when the health of the command is threatened by natural or other means.

## 1-31. COMMON COMMUNICABLE DISEASES

Viral hepatitis, venereal diseases, tuberculosis, and malaria are all examples of common communicable diseases which must be reported. Refer to your local SOP and AR 40-400, Patient Administration, for the current complete list of reportable diseases and the method of reporting.

a. **Viral Hepatitis (Types A, B, Non-A, and Non-B).** Usually, the following information is reported in a special telegraphic report:

- (1) Total number of cases without mention of the specific viral type.
- (2) Total number of cases that were determined to be hepatitis B surface antigen (HBsAg) positive, HBsAg negative, and in which HBsAg test results were unknown.
- (3) Total number of cases where hepatitis A (IgM) antibody test was positive (indicating recent infection), IgM antibody test was negative, and in which IgM test results were unknown.
- (4) Suspected vehicle or cause of outbreak such as food, water, or parenteral drug use.

b. **Malaria.** The following data will be listed specifically when a final diagnosis of malaria has been made.

- (1) Date of illness onset and the specific plasmodium species.
- (2) Patient's location and place of treatment at the time the current attack began.

(3) History of previous attacks.

(4) Dates and places of oversea tours (civilian and military) during preceding period (ten years for infection with plasmodium malariae, two years for infections with other plasmodia).

(5) History of antimalarial prophylaxis, including the name of drugs taken.

(a) An information copy of the special telegraphic report will be mailed to this address:

Malaria Branch  
Division of Parasitic Diseases,  
Center for Infectious Diseases  
Centers for Disease Control  
Atlanta, GA 30333

(b) For each case of malaria diagnosed in CONUS, a Centers for Disease Control (CDC) Form 54.1 3/81, Malaria Case Surveillance Report, will be submitted to local or state health authorities. The form is available upon request from the Centers for Disease Control or State Health Department. These authorities will forward the form to the CDC.

## **1-32. INTERNATIONALLY QUARANTINABLE DISEASES**

Currently, cholera, yellow fever, and plague are diseases for which a person must be quarantined. Although the World Health Organization has declared the world to be free of smallpox, if a case of this disease does occur, it is internationally quarantinable.

**Continue with Exercises**

## EXERCISES, LESSON 1

**INSTRUCTIONS.** The following exercises are to be answered by marking the response that best answers the question or best completes the incomplete statement or by writing the answer in the space provided.

After you have completed all the exercises, turn to the solutions at the end of the lesson and check your answers. For each exercise answered incorrectly, reread the material referenced after the solution.

1. List two military reasons for immunizing soldiers.
  - a. \_\_\_\_\_.
  - b. \_\_\_\_\_.
  
2. Name four groups of people eligible for the Army Immunization Program.
  - a. \_\_\_\_\_.
  - b. \_\_\_\_\_.
  - c. \_\_\_\_\_.
  - d. \_\_\_\_\_.
  
3. Because of certain religious beliefs, a soldier does not want to be immunized. Circle the letter of each statement that applies to this soldier's situation.
  - a. The commanding officer at the local medical treatment facility should grant the soldier an exemption.
  - b. If granted an exemption, the soldier would have no assignment limitations.
  - c. The Surgeon General could grant the soldier a permanent waiver.
  - d. Under a permanent waiver, the soldier could not be stationed in areas in which cholera was prevalent.
  - e. A permanent waiver, if granted, would be subject to being revoked.
  - f. If a permanent waiver were granted, there would be places the soldier could not be assigned.

4. Match the definition in Column B with the word in Column A.

COLUMN A

COLUMN B

- |                           |  |
|---------------------------|--|
| a. Antigen _____          | 1. The part of human blood containing specific antibodies used to produce a short term passive immunity.   |
| b. Antibody _____         |  |
| c. Immunity _____.        | 2. A condition in which a body is not susceptible to a specific disease.   |
| d. Vaccine _____.         | 3. A foreign substance which can stimulate the body to produce antibodies.   |
| e. Toxoid _____.          | 4. A toxin which has been changed and weakened by one of the following: aging, a chemical process, cold, or heat.                                  |
| f. Immune globulin _____. | 5. A substance produced by the body in response to an antigen.   |
|                           | 6. A preparation of dead or weakened disease organisms used as an antigen instimulating the body to produce antibodies against a specific disease. |

5. A soldier had chickenpox and recovered.

- a. This soldier has now developed \_\_\_\_\_immunity.
- b. Since he had the disease, this soldier's body produced antibodies in about ten to \_\_\_\_\_ days.

6. John Smith, a civilian employee, has been selected for a position in Xanadu, a country in which measles is prevalent. John has never had measles. By receiving the measles immunization, John is acquiring \_\_\_\_\_ immunity.



7. A soldier has been bitten by a rabid bat and is in danger of becoming seriously ill. There is no time to wait for his body to build antibodies to fight against the disease. Therefore, this soldier will receive injections of ready-made antibodies to give him an immediate \_\_\_\_\_ immunity.
8. List two diseases for which live attenuated (weakened) immunizing agents can be used.
- a. \_\_\_\_\_.
- b. \_\_\_\_\_.
9. Name two diseases for which killed (dead) immunizing agents in the vaccine can be used.
- a. \_\_\_\_\_.
- b. \_\_\_\_\_.
10. List two diseases for which an exotoxin would be the immunizing agent.
- a. \_\_\_\_\_.
- b. \_\_\_\_\_.
11. Name two vaccines for which immune globulin would be the immunizing agent.
- a. \_\_\_\_\_.
- b. \_\_\_\_\_.
12. Most vaccines must be kept refrigerated/stored at at \_\_\_\_\_ to \_\_\_\_\_ °C (\_\_\_\_\_ to \_\_\_\_\_ °F)..

13. Yellow fever and polio virus vaccines require special treatment and must be stored below \_\_\_\_\_ °C (\_\_\_\_\_ °F).
14. On the outside of the door of the refrigerator where vaccines are stored, keep a record of the \_\_\_\_\_ and \_\_\_\_\_ it twice a day.
15. If there are any doubts about the vaccine (it looks strange; you suspect it has not been properly stored \_\_\_\_\_).
16. List the three safe methods of disposing of live vaccines, containers, and syringes having come in contact with live vaccines.
- a. \_\_\_\_\_.
  - b. \_\_\_\_\_.
  - c. \_\_\_\_\_.
17. If a person is going to have an acute anaphylactic reaction to an immunization, the reaction will probably occur within \_\_\_\_\_.
18. List the two immunizations required for foreign travel.
- a. \_\_\_\_\_,
  - b. \_\_\_\_\_.
19. Name three immunizations that are recommended for foreign travel.
- a. \_\_\_\_\_.
  - b. \_\_\_\_\_.
  - c. \_\_\_\_\_.

20. Each soldier has two records of immunization: PHS-731 (International Certificates of Vaccination) and Standard Form 601 (Health Record and Immunization Record).
- \_\_\_\_\_ stays with the soldier.
  - \_\_\_\_\_ is kept in the soldier's medical records.
21. Entries on PHS Form 731 may be based on the following:
- Immunization(s) administered at the facility where the form was prepared.
  - Transcripts from \_\_\_\_\_.
  - Transcripts from the written statement of \_\_\_\_\_ if sufficient information is given.
22. Be sure immunizations for \_\_\_\_\_ and \_\_\_\_\_ are current when you are traveling because the dates for these vaccinations (if required) will be checked.
23. Reactions to diphtheria immunizations are extremely rare; however, using \_\_\_\_\_ on adults can cause severe reactions.
24. Common reactions to pertussis vaccinations include hardness and tenderness at the injection site, malaise, and \_\_\_\_\_ fever.
25. Rare reactions to pertussis immunization include high fever of \_\_\_\_\_ °F, collapse but \_\_\_\_\_ recovery, screaming episodes, isolated convulsions, and disfunction of the \_\_\_\_\_.
26. Side effects from tetanus shots include local hardness and tenderness at the injection site and \_\_\_\_\_ fever.

27. Side effects from measles vaccination include fever, rash, and local reaction at \_\_\_\_\_ site.
28. List four communicable diseases that must be reported.
- a. \_\_\_\_\_.
  - b. \_\_\_\_\_.
  - c. \_\_\_\_\_.
  - d. \_\_\_\_\_.
29. List the four internationally quarantinable diseases.
- a. \_\_\_\_\_.
  - b. \_\_\_\_\_.
  - c. \_\_\_\_\_.
  - d. \_\_\_\_\_.
30. Report to the local Preventive Medicine Service (PMS) all cases of diseases listed in \_\_\_\_\_.
31. Refer to \_\_\_\_\_ for guidance on how to report cases of diseases occurring in greater than expected numbers.

**Check Your Answers on Next Page**

## SOLUTIONS TO EXERCISES, LESSON 1

1. Conserve the fighting strength by preventing diseases.  
Prevent delay and detention in travel (by preventing diseases). (para 1-2b)
2. You are correct if you named any four of the following:  
  
Active duty personnel.)  
Alert forces.  
Reserve component personnel.  
Military dependents.  
Federal civilian employees and dependents.  
Foreign nationals.  
Other personnel under Armed Forces auspices.  
(paras 1-3a-g)
3. c. The Surgeon General could grant the soldier a permanent waiver.  
e. A permanent waiver, if granted, would be subject to being revoked.  
f. If a permanent waiver were granted, there might be places where the soldier would not be assigned. (para 1-9a)
4. a. 3.  
b. 5.  
c. 2.  
d. 6.  
e. 4.  
f. 1. (paras 1-10a(1)-(6))
5. a. Active. (para 1-11a)  
b. 14. (para 1-11b)
6. Active artificial. (para 1-12a(1))
7. Passive. (para 1-12b)
8. You are correct if you listed any two of the following:  
  
Rubella.  
Measles.  
Mumps.  
Smallpox.  
Polio.  
Adenovirus.  
Yellow fever. (paras 1-12a(1)(a)-(g))

9. You are correct if you wrote any two of the following:
- Typhoid.
  - Cholera.
  - Influenza.
  - Plague.
  - Meningococcal. (paras 1-12a(2)(a)-(e))
10. You are correct if you wrote any two of the following:
- Tetanus.
  - Diphtheria.
  - Anthrax (para 1-12a(3)(a)-(c))
11. Measles immune globulin.  
Human rabies immune globulin (HRIG). (para 1-12b)
12. 2 to 8° C; 35.6 to 46.4° F. (para 1-18c)
13. Below 0° C; below 32° F. (paras 1-18a, b)
14. Temperature; record. (para 1-18c)
15. Return the vaccine to the appropriate source (pharmacy, etc.) with notations.  
(para 1-18d)
16. Burning.  
Boiling.  
Autoclaving. (para 1-19)
17. 30 minutes. (para 1-14)
18. Cholera.  
Yellow fever. (para 1-21)
19. You are correct if you listed any three of the following:
- Plague.
  - Rabies.
  - Typhoid.
  - Typhus.
  - Tuberculosis.
  - Hepatitis. (paras 1-22a-f)
20. a. PHS 731. (para 1-24)  
b. SF 601. (para 1-25)

21. b. Official records.  
c. Civilian physicians. (paras 1-24c(2), (3))
22. Yellow fever.  
Cholera. (para 1-21d)
23. Pediatric preparations. (para 1-16a)
24. Mild to moderate fever. (para 1-16b)
25. 105° F. (para 1-16b(1))  
Rapid. (para 1-16b(2))  
Brain. (para 1-16b(5))
26. Mild. (para 1-16c)
27. The injection. (para 1-16d)
28. Viral hepatitis.  
Venereal disease.  
Tuberculosis.  
Malaria. (para 1-31)
29. a. Smallpox.  
b. Cholera.  
c. Yellow fever.  
d. Plague. (para 1-32)
30. AR 40-400. (para 1-31)
31. Local SOP. (para 1-31)

**End of Lesson 1**

## LESSON ASSIGNMENT

### LESSON 2

Ionization, Microwave, and Laser Injuries.

### LESSON ASSIGNMENT

Paragraphs 2-1 through 2-19.

### LESSON OBJECTIVES

After completing this lesson, you should be able to:

- 2-1. Define ionizing/nonionizing radiation and identify the sources, characteristics, biological effects, and control measures in the military of ionizing/nonionizing radiation.
- 2-2. Define microwave radiation and identify the sources, characteristics, biological effects, and control measures in the military of microwave radiation.
- 2-3. Define laser radiation and identify the sources, characteristics, biological effects, control measures in the military, first aid for laser injuries, and safety principles for laser radiation.

### SUGGESTION

After completing the assignment, complete the exercises of this lesson. These exercises will help you to achieve the lesson objectives.



## LESSON 2

### IONIZATION, MICROWAVE, AND LASER INJURIES

#### Section I. IONIZING AND NONIONIZING RADIATION

##### 2-1. INTRODUCTION

The earth is full of radiation, some natural and some man-made. Radiation is in the air we breathe, the water we drink, and the ground we walk on. Man has added to the natural radiation in the form of medical and dental x-rays, the mining of uranium, and nuclear weapons and power plants. With the increasing use of radiation in all phases of our lives--in peacetime and war--it is essential to understand the fundamentals of radiation and to be prepared to treat the victims of the misuse of radiation or radiation accident.

##### 2-2. DEFINITION

a. Radiation is the transmission of energy in the form of waves or particles. Two forms of radiation that are not usually harmful to the body are visible light and sound (nonionizing radiation). Ionizing radiation is radiation that has the ability to change atoms in the body into their basic charged particles (ions). Ionizing radiation causes problems in the molecules of various body tissues. Depending on the extent of exposure, a person may die early or suffer complications such as leukemia.

b. Of the four basic types of nuclear particles, three are ionizing radiation: alpha particles, beta particles, and gamma rays. A neutron, an uncharged atomic particle found in the center of all atoms except hydrogen, is the fourth basic type of nuclear particle. See figure 2-1

(1) Alpha particles. These particles represent the nucleus of the atom and are rather large, slow moving, positively charged particles. Alpha particles have a minimal penetrating ability and a very short range. A sheet of paper or skin can stop these particles. Unless they are inhaled or ingested, alpha particles probably will not damage the human body.

(2) Beta particles. These particles have a negative charge and correspond to the electron of an atom. Beta particles move a little faster than alpha particles and can, therefore, penetrate a little more than alpha particles. Heavy clothing can stop these particles. Beta particles would have to enter the body through the nose, mouth, or an open wound to cause damage.

(3) Gamma rays. Gamma rays are waves of energy with a velocity of the speed of light. They have high penetration power into the body and lead to gene mutations in humans. Gamma rays can only be stopped by substances such as thick concrete or lead shielding.

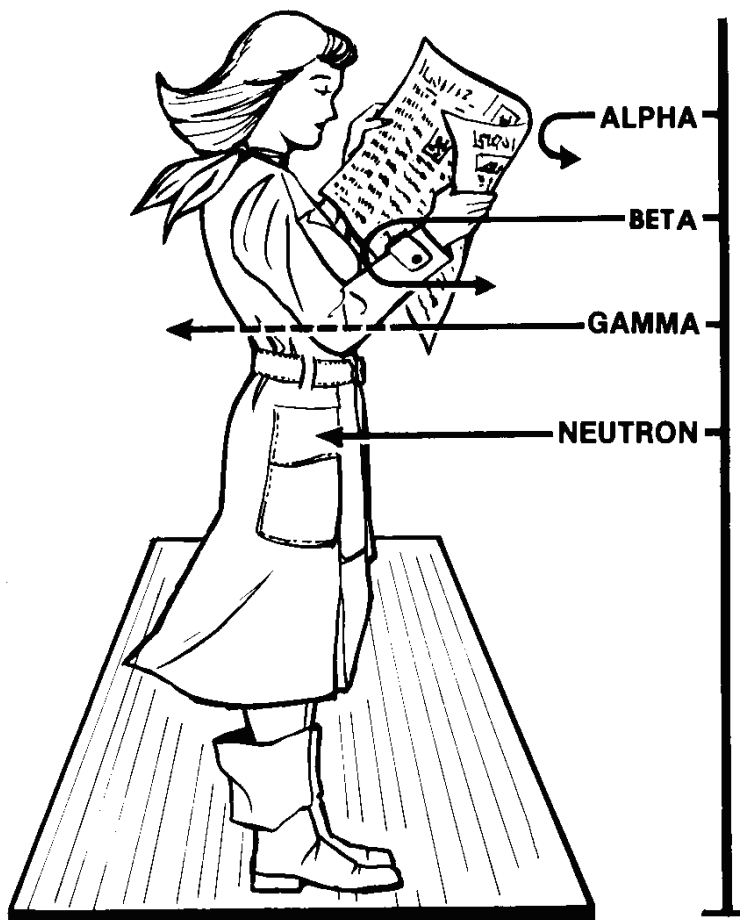

Figure 2-1. Four basic types of nuclear radiation.

(4) Neutron. A neutron is an electrically neutral or uncharged particle of matter which exists along with protons in the nucleus of all elements except the mass/isotopy of hydrogen.

c. At one time, scientists believed that the atom was the basic particle of all matter. Further inquiry and research revealed that the atom is actually composed of several smaller particles: electrons, protons, and neutrons. The proton has a positive charge, the electron has a negative charge, and the neutron has no electrical charge. In a specific element, all the atoms have the same number of electrons and protons. For example, all sodium atoms have the same number of electrons (11) and protons (11), and all calcium atoms have the same number of electrons (20) and protons(20). Until an atom's nuclear structure is excited by the addition of energy or mass, an atom is physically stable and electrically neutral. When the nucleus of an atom becomes excited, it becomes unstable and will of its own accord revert to its original stable condition. Subatomic particles (gamma radiation) are emitted during this change. This change during which there is a nuclear emission of mass or energy is called radioactivity, and the products released by radioactivity are called nuclear radiation.

## 2-3. SOURCES OF IONIZING/NONIONIZING RADIATION

Humans live in a world of radiation--some natural radiation which exists in the environment and some man-made radiation. This radiation is absorbed by the earth's inhabitants in varying doses.

### a. Natural Background Radiation.

(1) Cosmic rays. These rays are an important source of natural background radiation. Cosmic rays are particles which enter the earth's atmosphere at such great speed from outer space that they can penetrate many feet of matter. A single cosmic ray particle may produce a shower of secondary particles and radiations. Many of these particles are absorbed in the earth's atmosphere; therefore, the greater the altitude, the greater the cosmic ray radiation. This means that a person standing in Denver will receive more cosmic radiation than an individual standing at sea level in Los Angeles. This also means that people who are in airplanes frequently (such as pilots and flight attendants) are exposed to a great deal of cosmic radiation each year. The aircraft does not reduce the intensity of the radiation very much. Astronauts who travel through areas of intense radiation will also be exposed to cosmic radiation.

(2) Terrestrial radiation. Terrestrial means having to do with the earth; therefore, terrestrial radiation means radiation which comes from the earth. It is believed that there were radioactive particles in the earth's crust when the earth was formed. These radioactive particles are a source of radiation for people.

(a) Radiation comes from rocks, soil, and construction materials. At different geographic locations, there are different levels of radiation in the earth depending on the mineral composition of the soil and rock. Note the following:

1 Granite rocks have a higher level of radiation than basalt (lava rock).

2 Limestone and sandstone rocks are usually low in radiation.

3 Some shale rocks have a high level of radiation, particularly if the rocks have potassium salt in the fossil portions.

4 Uranium ore contains radiation in high levels.

(b) Plants may absorb radioactive particles in the soil or those particles may go from the soil into ground water, enter the food chain, and be eaten by people. Look at the list of items which come to people from terrestrial or earth radiation:

1 Potassium-40. This is abundant in nature and a large source of internal radiation in man.

2 Radioactive gas radon. This comes from the disintegration of radium. It escapes from soil and rocks into the atmosphere. It enters the body by people inhaling the substance when they breathe.

3 Carbon-14. This is a substance produced in the atmosphere; all living material has some carbon-14.

#### **b. Man-Made Radiation.**

(1) Medical radiation. Today, people may be exposed to two types of radiation: diagnostic radiation (dental x-rays, chest x-rays) or therapeutic radiation (radiation to treat a disease). X-rays can be taken of any part of the body. By means of x-ray, the doctor can see problems in the kidney, possible broken bones, congestion in the lungs, and other problems. When proper precautions are taken, such as the use of protective devices and reasonable limitations to the use of radiation, there are great benefits to the physician.

(2) Industrial radiation. A variety of devices using various types of radiation exist in the world today. Some are as sophisticated and complex as nuclear generators and reactors, while others are as ordinary as the microwave ovens used to dry potato chips. Other radiation equipment is used to test new products. These and many more radiation devices are all potential sources of radiation to people.

(3) Fallout. Most publicized is fallout from nuclear explosions. Particles from surface explosions, shallow surface reactions, or low air bursts are capable of producing radioactive contamination over large areas next to the explosion site. The residue may be so great as to be a biological hazard. Delayed fallout (fallout which comes after the first day) consists of very fine, invisible particles which settle in low concentration over a large area of the earth's surface. If the fallout is from a surface burst, a fireball may interact with surface earth and water. The strong after-winds at the surface of the earth will cause large amounts of earth or water to be sucked up as the fireball rises. As this mass cools, the radioactive particles of earth and water fall to earth contaminating the area in which they drop.

(4) Radiation from other sources. There are other sources of radiation in addition to the sources just discussed (natural background radiation, environmental contamination radiation, and medical radiation).

(a) Radium in watches/clocks. For many years, radium was used for the luminous markings on watch and clock dials. Enough radium was used so that people who made the watches, sold the watches, or wore the watches were exposed to radiation from the radium.

(b) X-ray fluoroscopy for shoe fitting. At one time in the United States, it was common for a person (particularly a child) to try on a new pair of shoes in a shoe store and step into a machine which would x-ray the feet showing whether or not the shoes fit. The machine (the x-ray fluoroscope) has been prohibited in several countries because it caused unnecessary radiation exposure.

(c) Television sets. A small amount of radiation is released by television sets. More radiation is released by a color television set than a black-and-white set. The plastic or glass covering on the sets reduces the radiation dosage considerably. Additional shielding is necessary for color television sets.

## 2-4. CHARACTERISTICS OF IONIZING/NONIONIZING RADIATION

- a. The speed of this type of radiation approaches, or equals, the speed of light.
- b. Ionizing radiation travels in straight lines although some radiation scatter is possible.
- c. The range of penetration into the human body for ionizing radiation varies.
  - (1) Alpha particles. An alpha particle does damage for only a short distance and penetrates the human body less than one-thousandth of a centimeter.
  - (2) Beta particles. Beta particles can travel a little longer in the air and penetrate human tissue a little deeper (0.2 inches).
  - (3) Gamma rays and x-rays. These rays, from natural radiation outside the body, can penetrate deeply and do the body more injury than either alpha particles or beta particles.
- d. Air can absorb alpha particles, beta particles, and neutrons very well. Gamma rays are not well-absorbed by air.

## 2-5. BIOLOGIC EFFECTS

a. **Effects on Somatic (Body) Cells.** Radiation can produce cancer in humans. Sometimes cells in an area of the body go out of control and duplicate in an unusually large number. The result is an excess of tissue which is called a growth or tumor. If the growth is cancerous (malignant), the cells--still out of control--will spread to other parts of the body, sometimes very quickly. These cancerous cells, lacking a quality called contact inhibition, can invade and kill healthy tissues. Along with substances in the air we breathe, the water we drink, and the food we eat, radiation is one of the environmental factors that can cause cancerous cells. Skin cancer, for example, may be caused by ultraviolet light from the sun.

**b. Genetic Mutations in Future Generations.** Radiation can have two major genetic effects on humans. First, a gene mutation may occur (a permanent, transmissible change in the gene function). Many of these gene mutations are recessive and only show up when two people with the same recessive gene pair. Second, radiation can result in chromosome breakage. Chromosome breakage involves multiple genes and may lead to fetal death. Chromosome breakage does not have a long-range hidden hazard. When radiation exposure takes place over an extended period, rather than all at one time, fewer gene mutations occur. Based on current knowledge, gene mutations are not regarded by scientists as a serious problem.

**c. Effects on Developing Embryo or Fetus.** The damage done by radiation depends on the gestation stage at which the radiation occurs.

(1) Preimplantation period. (Conception through the 9th day.) During this period, the fertilized egg is embedded in the wall of the uterus where it divides rapidly. Radiation during this period can cause the death of the embryo. However, if the embryo survives, it will develop normally.

(2) Organogenesis period. (From the 10th to the 49th day.) The individualized, specialized organs begin to form during this period. Radiation at this time can result in temporary growth retardation. The principal and more serious effects are gross abnormalities and structural deformities. There may be a cleft palate, stunted arms or legs, or an abnormally developed brain. These abnormalities are indistinguishable from the same abnormalities that occur in about four percent of all births.

(3) Fetal period. (After the 49th day.) If the radiation has occurred early in the fetal period, there is growth retardation that is permanent and lasts into adulthood. Additionally, the diameter of the head is smaller and there is mental retardation.

**d. Acute Total Body Irradiation.** There is a characteristic pattern of injury if the person's entire body is exposed to penetrating ionizing radiation. Effects of radiation on the body can be categorized according to rems (the measure of quantity of radiation) the person is exposed to.

(1) Cases of people receiving 10,000 rem in accidents. The result is usually cerebrovascular death. Within an hour after exposure, a person experiences vomiting and diarrhea. Next, there are mental changes and fall of blood pressure, then convulsions and unconsciousness. Within one to three days, the person will die from cerebrovascular problems.

(2) Cases of people receiving 2,000 rem. Gastrointestinal failure is the cause of death. Within a few hours of exposure, the person suffers nausea, vomiting, and diarrhea--all of which become progressively worse. Then, there is fever, loss of fluids, and loss of soluble salts. Finally, gross infections lead to death.

(3) Cases of people receiving a few hundred rem. Some individuals survive, but others die as a result of failure of blood-forming organs. These doses of radiation have very little effect on the circulating blood. Instead, the radiation kills the primitive stem cells in the bone marrow, lymph nodes, and spleen. These primitive cells produce the replacements for the circulating blood.

(a) For about a month after the exposure to radiation, an individual has brief periods of nausea.

(b) At the end of that month, the mature circulating blood cells have reached the end of their lives and die. Because the primitive stem cells cannot produce replacement cells, the exposed person begins to suffer hemorrhages caused by the lack of platelet cells necessary for blood clotting. The individual becomes tired and weak from anemia. Also, there is a risk of infection because of the absence of protective white blood cells.

(4) Cases of people receiving 325 rem. About half of the healthy adults who are exposed to radiation will die. Very young people and very old people may be very sensitive to even this low amount of radiation. Some people may be saved with medical help--antibiotics, blood transfusions, or bone marrow transplants.

e. **Acute Local Irradiation.** If only specific parts of the body are exposed to radiation, the body can tolerate a higher amount of radiation. Also, much of the bone marrow will not be exposed to radiation and can, therefore, continue to form blood cells. For example, in radiation therapy for cancer, normal tissues can tolerate a dose of 6,000 to 7,000 rads delivered over a period of six to seven weeks. These doses may be enough to stop permanently the growth of many cancers.

(1) Larger accidental doses of radiation result in severe tissue damage and necrosis. (Necrosis refers to changes resulting in cell death.) Groups of cells or part of a structure or an organ may be affected.

(2) After exposure to radiation has occurred, there is no known treatment to stop the development of the injury. Sometimes dead tissue can be removed surgically. Repair can be done by plastic surgery if the tissues surrounding the injury are not too badly injured.

## **2-6. CONTROL MEASURES IN THE MILITARY**

a. **The Radiation Protection Officer (RPO).** The RPO, a full-time or extra-duty assignment, is responsible for the following.

(1) Maintaining inventories.

- (2) Conducting surveys of leakage or exposure to radioactive sources.
- (3) Enforcing the standing operating procedures (SOPs).

**b. Surveillance Programs.**

(1) Physical. A complete physical should be given periodically with particular attention given to any specific complaint. A specific complaint may be an indication of too much exposure to radiation.

(2) Bioassay for radioisotopes. This test is performed if it is suspected that an individual has been overexposed to radiation. For example, suppose an individual has been working in a laboratory around radioactive material. There is a possibility that he has been exposed to too much radiation. A blood sample is taken and put in a machine which counts the amount of radioactivity. That amount is compared to the standard amount.

(3) Film badge program. This program is a way of tracking the amount of radiation an individual working with or around radiation accumulates. The individual is given a badge on which his assigned number appears. The badge measures the amount of radiation his body receives each day. Periodically, the badge is checked to see whether the accumulated amount of radiation the person has received is normal or excessive. If he has received too much radiation, there may be a leak in the equipment that must be fixed. Suppose this person leaves this job and works in an area without radiation. After a year, he returns to a job in an area where there is radiation. He puts on his badge again and the badge continues to record the radiation his body is receiving. This amount of radiation is added to the total amount of the previous radiation.

**c. Methods to Reduce Exposure.**

(1) Time. Keep the length of time personnel are exposed to radiation to a minimum. The total radiation dose equals the radiation dose per hour times the exposure time. Keep the exposure time for each individual as low as possible.

(2) Distance. The farther away a person is from the radiation source, the better (see formula). If you move twice the distance away from the radiation source, your exposure is lowered to one-fourth. Move three times the distance away, and your exposure is reduced to one-ninth as much as before. Remember, then, that moving even a small distance away, 10 or 20 feet, reduces exposure considerably.

$$\text{EXPOSURE} = \frac{1}{(\text{distance})^2}$$



(3) Shielding. The clothing you wear can give you adequate protection from alpha and beta radiation. Wear a filtration mask to prevent inhaling radiation. Do not eat or drink in a contaminated environment. To protect yourself from gamma rays, you must be on the other side of a lead shield from the gamma ray source. It is more practical in the field to shield the source of the gamma rays.

## Section II. MICROWAVE RADIATION

### 2-7. DEFINITION

Our universe is full of waves, some of which we can see such as visible light waves and others which we can feel such as heat waves. The total radiation of wavelengths from radio waves to gamma rays is called the electromagnetic spectrum (figure 2-2) The part of the spectrum that is useful for radio transmission is called the radio frequency region. The radio frequency covers a large part of the spectrum of electromagnetic waves. Microwaves are very short radio waves with wavelengths of about 0.1 to 30 centimeters.

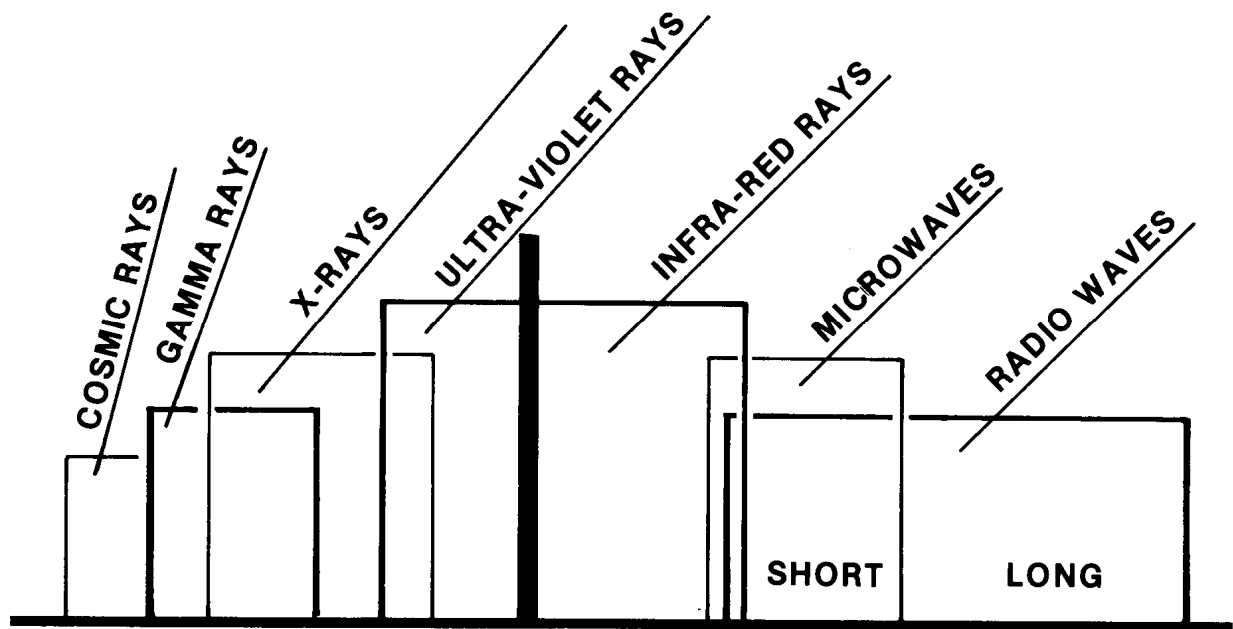

Figure 2-2. Electromagnetic spectrum.

### 2-8. SOURCES

Almost every aspect of human life today is affected by developments in electromagnetic technology, particularly in the field of microwave technology. There are applications of microwave technology in industrial, scientific, medical, and military devices.

### a. Microwave Heating Devices.

(1) Microwave ovens. When the word microwave is used, most people probably immediately think of microwave ovens (figure 2-3). The microwave oven has been used for years for food preparation in restaurants and the military and is used inside homes.

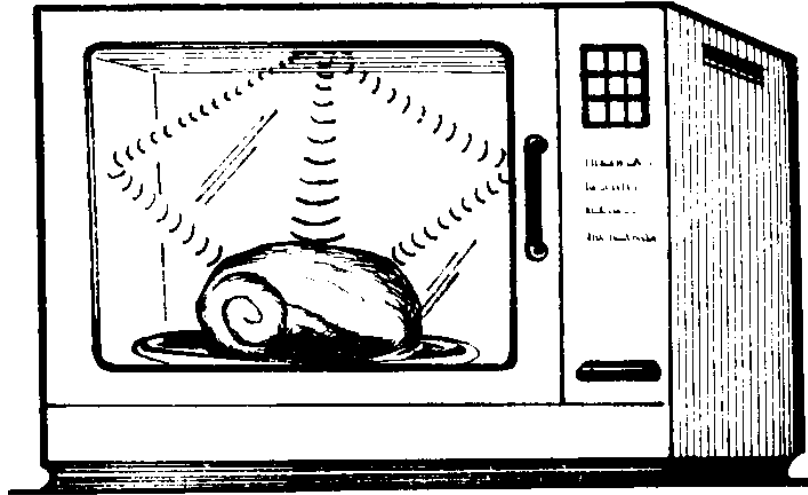

Figure 2-3. Cooking by microwaves--the microwave oven.

(a) Microwave oven operation is described below.

1 Microwaves flip the tiny molecules that make up the food backward and forward. This causes heat by friction.

2 In the microwave oven, there is a valve called a magnetron. This valve causes microwaves to move along a waveguide and into the oven.

3 These waves swing back and forth through the food being cooked, flipping the molecules in the food back and forth.

4 The flipping molecules in the food heat up. As the food molecules heat up, the food is cooked.

(b) Advantages of microwave cooking are:

1 Only the food is heated, not the oven walls; therefore, the oven is easily cleaned and cooking is more efficient.

2 The food is cooked throughout rather than only from the surface inward (as in conventional ovens).

3 The cooking time is usually reduced to a few minutes rather than hours.

(2) Commercial processes. Since microwaves are excellent in heating and drying uniformly and rapidly, microwaves are used commercially to:

- (a) Dry potato chips (in the process of making potato chips).
- (b) Dry glue binds in plywood manufacturing.
- (c) Dry high-speed photographic film.

(3) Medical use.

(a) The microwave autoclave. It has been demonstrated that the microwave autoclave (sterilizer) slows down bacterial and viral growth and also makes enzymes inactive.

(b) Diathermy machine. Microwave radiation has been used for many years in diathermy machines to heat tissue internally. The advantage of microwave energy is that it can localize the heat in order to treat muscle pain without heating the surrounding tissue.

(c) Biological research. Microwaves are used in biological research whenever heating must be carefully controlled.

#### **b. Conveying Information.**

(1) Microwave application. The most common application of microwaves is in radar and communication networks. Both fields have grown tremendously along with the growth of the computer industry since computers are now an integral part of almost all modern radar and communications systems.

(2) Radar. Radar consists of a microwave transmitter used to send out a beam of radiation. This beam of radiation travels in a straight line until it strikes an object, such as an airplane, which reflects the beam back to a receiver (figure 2-4). Using sophisticated electronic techniques, a person can obtain information about the speed of the plane, its range, direction of travel, and even the type of aircraft. Determining speed and direction of travel is the simplest use of radar. Some other uses of radar follow.

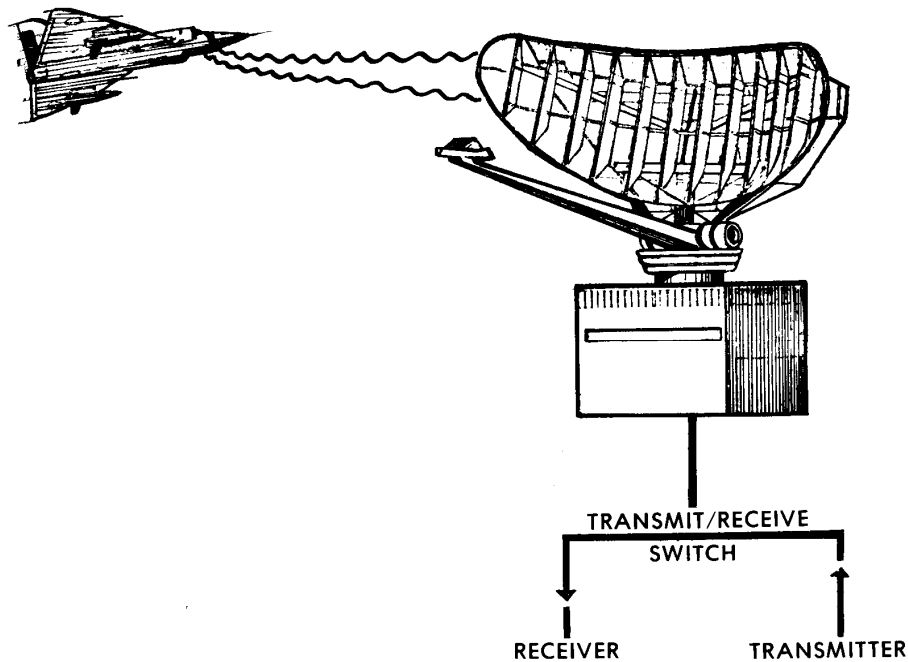

Figure 2-4. Radar.

(a) Military uses.

- 1 Radar can guide missiles to their targets.
- 2 Radar can aim artillery at enemy aircraft.
- 3 Radar can control moon probes to soft landings.
- 4 Radar can map out ground areas from the air and measure the depth of land contours beneath the ice in Greenland and Antarctica.

(b) Civilian uses.

- 1 Radar is used to monitor commercial aircraft for safe air traffic control.
- 2 Radar is used to hunt out weather disturbances by spotting cloud formations.
- 3 More recently, radar is used in stores to detect shoplifters. All store items have radar detectable markers.
- 4 Familiar to us all, radar is used by the police to monitor the speed at which we are driving.

c. **Power Transmission.** It is possible that future generations may get power for their needs via microwaves. One advantage would be that microwave transmission (the power) would take place through waveguides which would look like large insulated water pipes. Less power would be lost than is now lost when power is transmitted over high-voltage power cables. To date, it is still inefficient to convert microwave energy to electrical energy.

d. **Microwave Spectroscopy.** A microwave spectroscope is a tool used in basic research to examine the internal structure of materials in the same way x-radiation is used.

## 2-9. CHARACTERISTICS OF MICROWAVE RADIATION

a. **Electromagnetic Nature.** Microwaves are one part of the waves in the electromagnetic spectrum. These invisible waves move outward traveling in an up-and-down movement (figure 2-5). These waves travel outward in all directions from the transmitting antenna. The more powerful the waves, the farther they travel through space.

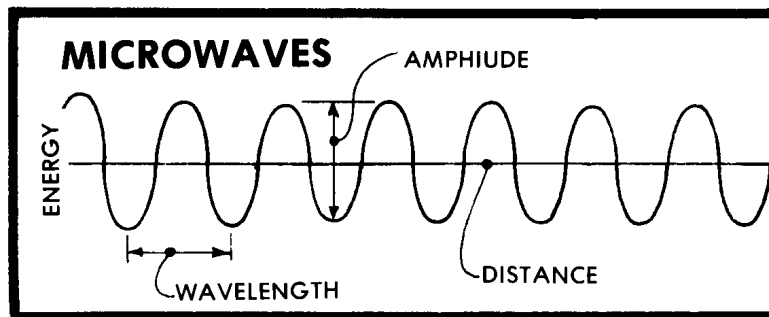

Figure 2-5. Microwaves.

- (1) Like ordinary radio waves, microwaves can be modulated (changed according to the sound wave).
- (2) Microwaves can carry sound waves.
- (3) Microwaves (short waves) are transmitted in narrow beams.
- (4) For transmission, microwaves need special antennas, usually shaped like a bowl.
- (5) Microwaves cannot be sent on ordinary wires. They must be sent through special pipes called waveguides.

b. **Nonionizing.** Microwave radiation does not cause ionization. That is, microwaves do not cause atoms to separate or change into ions.

c. **Reflection, Transmission, or Absorption.** Microwave radiation travels in straight lines and is reflected, transmitted, or absorbed. When microwave energy strikes a surface, it can be reflected back from that surface in the same way that a mirror reflects back the light that hits the mirror. How well the surface reflects back microwaves depends on the efficiency of the surface as a reflector. Large, smooth, metal surfaces like copper are very efficient reflectors of microwaves; these surfaces reflect nearly all of the energy carried by microwaves. The earth's surface is a fairly good reflector of microwave radiation. The ionosphere, even though its surface is not as reflective as a mirror, is also a fairly good reflector of microwave radiation.

## 2-10. CONTROL MEASURES

a. **Inspection.** Frequent inspections are conducted for leaks or tears in the seals of microwave devices.

(1) Inspection guidelines -- microwave ovens. It is impossible to determine the exact amount a microwave cooking oven is leaking without suitable instrumentation, but there are some visual checks that can be made. Almost all instances of leakages are around the door area; therefore, checks for the following should be made.

- (a) Loose or bent hinges and screws missing from door hinges.
- (b) Sprung, warped, or misaligned doors.
- (c) Faculty interlocks; for example, the oven should not be operable with the door open or slightly ajar.
- (d) Worn, missing, or damaged seals around the door or viewing area.
- (e) Pitting and burn spots around the periphery of the door closure area. This is usually caused by arcing as a result of grease buildup around the door. Check ovens at frequent intervals to eliminate this arcing which causes an increase in leakage levels.
- (f) Reflection from metal objects can increase leakage; therefore, check to be sure personnel are not using metal or aluminum foil cooking containers.
- (g) Be sure ovens are not being operated empty. If you want to operate the oven without food to check its operation; for example, the door locks, put a small bowl or beaker of water in the oven.
- (h) Be sure appropriate operating signs are posted.

(2) Survey -- detection equipment microwave ovens. The Narda 8200 is the approved instrument for making leakage tests. This device will measure leakage levels from about 0.1 mW/cm<sup>2</sup>, is battery-operated, easy to use, and covers the most popular oven frequency of 2450 MHz.

b. **Medical Surveillance.** Personnel working around microwave devices are monitored for health problems.

c. **Access Control.**

(1) There should be limited access to the areas where microwave equipment is in use. Warning signs, identifying potentially harmful microwave devices, are posted where microwave devices such as radars and communication systems are in use. See figure 2-6.



Figure 2-6. Example--radiation warning sign.

(2) Microwave radiation can also be transmitted by the substance it hits. The radiated energy that comes in contact with the substance passes through without any loss of energy. If microwave radiation hits a substance that can absorb, the radiation is absorbed. The radiated energy is neither reflected by the substance nor transmitted through it. The energy dissipates within the substance.

## 2-11. BIOLOGICAL EFFECTS

a. **Thermal Damage.** If the microwave radiation is sufficiently intense, the human body absorbs and is heated by the radiation, which may cause the following:

- (1) Hyperthermia--abnormally elevated body temperature.
- (2) Decreased sperm production--a temporary condition.
- (3) Cataractogenesis--cataract formation in the eyes.

b. **Nonthermal Effects.** Excessive microwave radiation may cause the following (not heat-related).

- (1) Nausea and epigastric distress.
- (2) Hearing problems.
- (3) Hematopoietic--problems in the formation of blood cells.
- (4) Central nervous system response changes:
  - (a) Irritability.
  - (b) Euphoria--abnormal or exaggerated sense of well-being.

## Section III. LASER RADIATION

### 2-12. DEFINITION

Laser technology is one of the most far-reaching developments of the 20th century. A laser light beam can be directed to do such widely different things as perform microscopic surgery, bore holes in diamonds, communicate over great distances, guide missiles and satellites, and trigger thermonuclear fusion. A laser is a very brilliant source of light. If all the light bulbs in the world were turned on at once, the result would not be the same as a beam from a single laser. Laser light is a different kind of light.

a. The word laser is an acronym made up of the first letter of each of these words: Light Amplification by Stimulated Emission of Radiation.



b. A laser is a source of light. Light is a form of energy. Light is called radiant energy because it flows, or radiates, out from its source (figure 2-7).

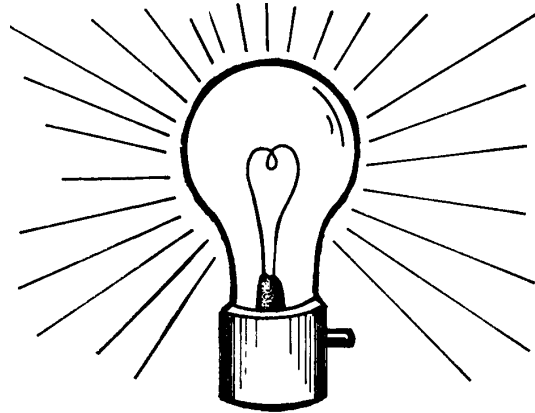

Figure 2-7. Radiant energy.

c. Amplification means to expand something--to make it bigger or stronger. Turning up the volume on the radio makes the sound louder; the sound has been amplified (figure 2-8). In regard to a laser, amplification means making the light brighter.

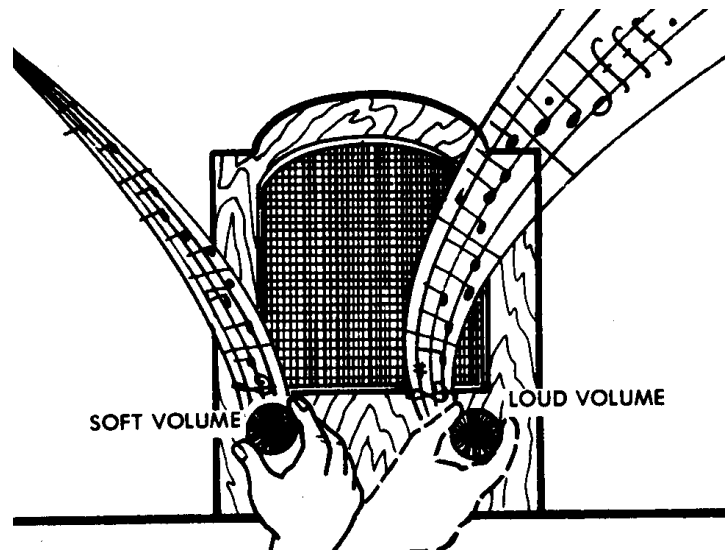

Figure 2-8. Amplification.

d. The words **stimulated** and **emission** go together. The concept comes from nature (figure 2-9). If the sun can store energy in coal, then surely a laser can store energy until there is enough to make a laser beam. Therefore, a laser is pumped so full of light energy that it cannot hold it all. Some light particles escape simultaneously setting other light particles free. That is, one light particle stimulates the emission of another light particle.

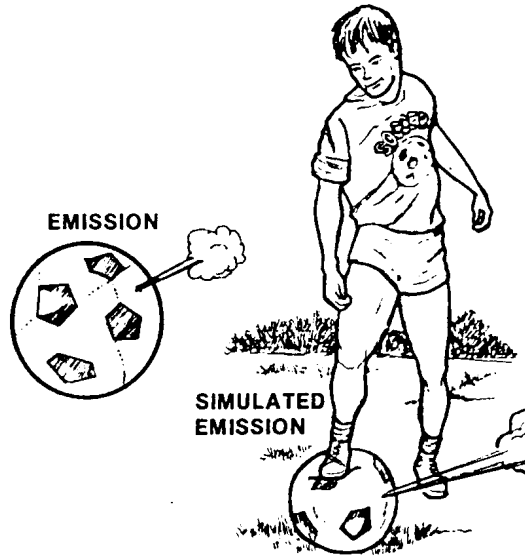

Figure 2-9. Simulated emission.

e. The word **radiation** refers to the fact that the energy released by the laser is in the form of radiating light waves. Light waves are sometimes called photons, a word which means a small bundle of light (figure 2-10). These particles of light energy radiate out from their source in a straight line.

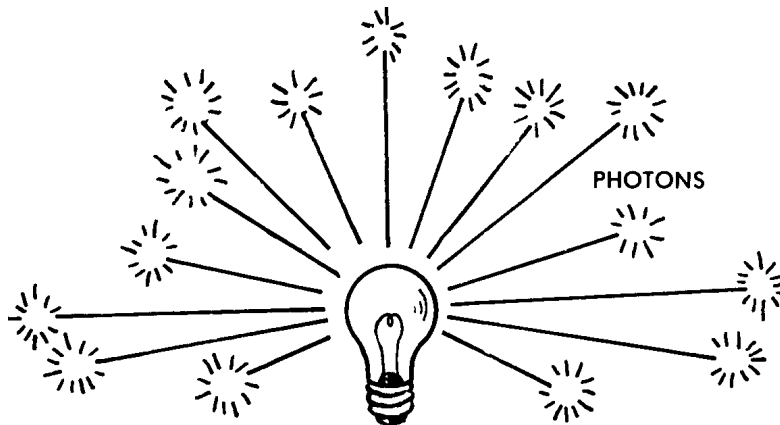

Figure 2-10. Photons.

f. Light travels in a wave that is up-and-down while still moving forward (figure 2-11). Think of a ball bouncing along a straight hallway. The ball bounces up and down while moving down the hall. A wavelength for light is the distance between bounces. Wavelengths are different for each color of light.

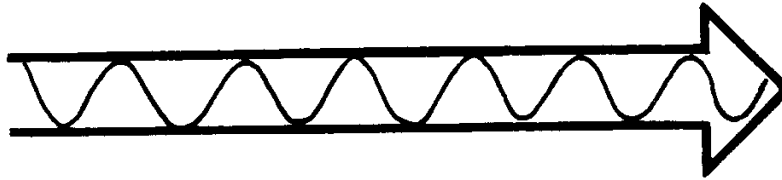

Figure 2-11. A light wave.

g. A laser is, then, light energy stored under pressure. When the pressure is great enough, that light energy is released in a huge, high-powered burst of light which is the laser beam. Laser beams have a wide variety of uses.

### 2-13. USES OF LASER RADIATION

a. **Point of Sale Device.** In the last 30 years, scientists have discovered more and more uses for lasers. The general public is probably unaware that the point of sale device in supermarkets functions by laser beam. The label, a series of parallel bars of varying widths, is put on an item by the manufacturer. At the checkout counter, the cashier moves that label across a focused laser beam. The laser beam scans the label, detects variations in the light and dark bands, and converts the variations to electrical signals. The price of the item is then identified and added to the customer's bill.

b. **Videodisc System.** The videodisc system, the space-age version of the phonograph needle, is another increasingly popular laser-base device. The videodisc is similar to a phonograph record. A major improvement is that the videodisc contains information that can be converted to a standard video signal for playback on the home television set. Information is put on the videodisc by laser beam, and the pictures on the videodisc are played by a focused laser beam. There are many advantages in this system. Since there is no needle to scratch or wear out the disc, there is no wear and tear on the disc. Much more information can be stored on the videodisc because a tightly focused laser beam is used in making the disc. It is easy to freeze a picture to look at; just maintain the laser beam on the same track.

#### c. **Military Application of Lasers.**

(1) In the armed forces, there are two types of use for laser beams: nondestructive use and destructive use. Nondestructive use includes a laser beam being used as a guidance device for range finding, tracking flying aircraft, and in battleground simulation on land. Destructively, it is possible to use high-powered laser equipment to project lethal laser beams at a target, destroying the target swiftly and instantly. That destruction can be accomplished by aiming a powerful pencil beam of laser at the target's strategic points and deactivating the functioning system of the target.

(2) Laser-beams have characteristics of particular value to the military. Laser beams can penetrate steel, titanium, and other hard metals to depths of more than a centimeter. They can cut and drill softer materials such as aluminum or magnesium alloys (used in aircraft structures) to depths of several centimeters under controlled process conditions.

(a) Laser range finder (military use). A laser range finder (figure 2-12) enables a weapons system to accurately gauge the distance to a target.

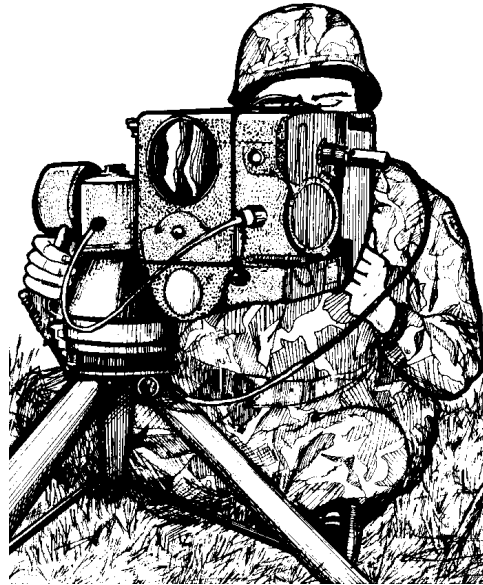

Figure 2-12. Soldier using laser beam range finder.

(b) Laser target designator. This is an instrument which pinpoints the target so that laser-guided weapons can be directed to their targets. To give exact location of a stationary or moving target in any day or night operation, the target designator is mounted on an aircraft. A target designator can also be held in a soldier's hand for the purpose of directing laser-guided bombs or missiles.

(c) Laser rifles for weapon simulation. Laser-equipped rifles are used to train soldiers in the field and indoors for marksmanship. A laser-beam transmitter is mounted on a rifle barrel and foresighted to the rifle. The laser output simulates bullets. The soldier squeezes the rifle trigger projecting a single pulse onto the target which is probably from 25 to 300 meters away. Hits are displayed on the target.

(d) Field training. In field training exercises (FTX) (battlefield maneuvers), each soldier is given a weapon-fire simulator, a helmet with PIN diodes, and a uniform which has detectors at the arms, body, and legs (figure 2-13). When any of the detectors are hit by a laser beam (figure 2-14), an audio alarm in the soldier's helmet goes off. At the same time, this action disables the soldier's rifle. The soldier has become a battlefield casualty after being hit by a laser beam rifle. MILES (multiple integrated laser engagement system) is the name of the simulated laser training system used by US soldiers. A major advantage of MILES is that it provides automatic feedback on the outcome of each independent weapon engagement (if the soldier is hit, a detector goes off immediately); training more like actual combat than the previously used cardboard targets which could not shoot back. Consequently, soldiers learn to respond to situations which could occur on the battlefield and to develop combat proficiency against skilled and determined opponents (those soldiers acting as the enemy).



Figure 2-13. Soldier with complete battleground outfit.



Figure 2-14. Soldier using a GaAs weapon simulator.

**NOTE:** Laser weapon simulators are used in machine guns, tanks, cannons, and artillery as well as air-to-air gunnery systems to train military personnel. The laser system is pulse-coded to identify the hit soldier, weapon, tank, etc.

d. **Security Surveillance Systems.** A laser-beam-aided security surveillance system can be used to detect unlawful happenings at strategic military grounds. The system can sound an alarm or produce a display on an instrument panel to alert the authorities of an intruder. Such a system can be used in and around military installations. The system can also be used for private purposes to protect civilian property against vandals, thieves, arsonists, and other criminals. Such systems have been put into service in the past with ordinary white light as detectors. A bird, cat, or dog could trip the system by crossing the path of the beam. The central station was notified, but the notification was an accident. Now, with the advent of laser beams, the light beam is invisible and of high intensity and can be directed to indicate exactly where something happened.

e. **Range Finders.** Range finders are instruments used to measure distances. Laser range finders and radar range finders work much the same way (figure 2-15). Each sends out a signal to an object. By knowing the time it took for the signal to get to the object and bounce back to the sender, the distance from the sender to the object can be determined. The weakness of using radio waves is that they are bigger than light waves and become weaker as they travel (they run into interference). Laser range finders, traveling greater distances, can be used to keep track of rockets and satellites. Accurate measurements in land surveys and construction work can be made with laser range finders. Scientists in a laboratory can measure the space between two atoms by using a laser range finder.

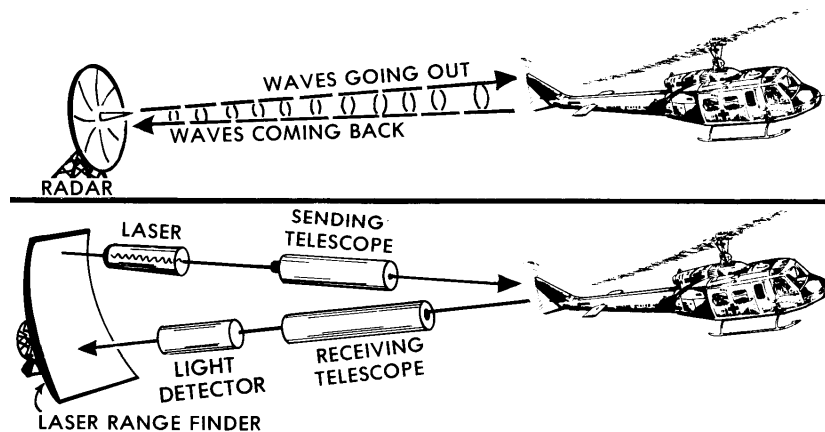

Figure 2-15. Measuring distances by laser beam.

f. **Communications.** Like radio waves, laser beams can be used to send communications signals (telephone, television, and radio) (see figure 2-16). Astronauts in space have communicated to earth by laser beam. Laser communications go through space better than through the earth's atmosphere. The reason is that in space there are no clouds, rain, snow, or smog to weaken the laser beam's power.

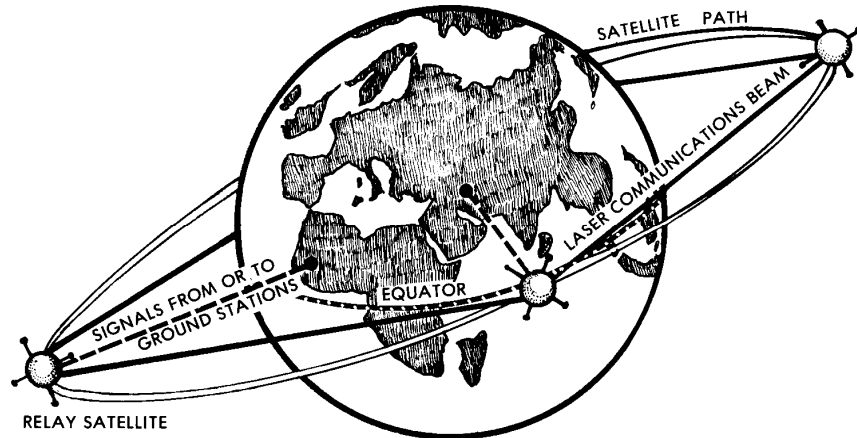

Figure 2-16. Communications with laser beam.

g. **Medicine.**

(1) The laser beam is of great value in surgery because the beam can be focused to a fine point by a single optical lens. This results in sufficient power density to vaporize tissue giving a sharp, clean incision. There is little or no bleeding since blood vessels are cauterized by the heat of the laser beam and once the vaporized material is suctioned off, the entire site is free of debris. The depth of the cut is adjusted by reducing the beam focus and increasing the scan speed. When laser surgery is being performed, wet towels must be draped over exposed metal, and nonexplosive anesthetic gases must be used.

(2) Ophthalmologists have needed an intense beam of light which could be focused into small areas at the back of the eyeball to weld a detached and torn retina. Today a very carefully controlled laser beam can fill that need (figure 2-17). The retina, which captures images of the things we see, sometimes comes loose from the back of the eye. This causes poor vision. A low-power laser beam the size of a pinpoint can pass through the clear parts of the eye. When the beam hits the retina, the photons pile up welding the damaged area back in place.

(3) Dermatologist can use laser beams to remove marks on dark skin areas since laser beam light is absorbed by dark areas. Therefore, persons with portwine birth marks, tatoos, melanomas, and basal cell carcinomas can have these removed with a Ruby laser.

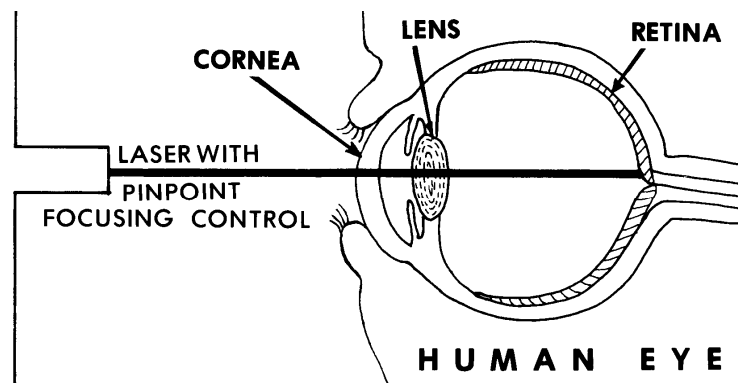

Figure 2-17. Eye surgery with laser beam.

h. **Measuring the Environment.** Lasers can be used to study and measure air pollution. The Los Angeles basin is frequently plagued with photochemical smog. Chemicals in the exhaust from automobiles, trucks, buses, etc., react with each other and the oxygen in the air. They become attached to particles of dust or droplets of water, causing smog. This type of pollution can be studied by drawing a sample of the polluted air in a special measuring cell and scanning it with a tunable laser.

NOTE: Tunable lasers are lasers in which the wavelengths of laser light can be adjusted.

i. **Air Turbulence Studies.** Laser beams are used in determining the drag coefficient on new cars. The drag coefficient refers to the amount of resistance an automobile creates against the wind when the car is traveling at different speeds. The goal is to design an automobile with as little resistance to wind as possible. The engine of an automobile with a reduced resistance to wind does not work as hard as the engine of an automobile with a higher resistance to wind. The result is that the first automobile gets more miles to the gallon in gas mileage.

j. **Holography.** The word "holo" means whole and "graph" means picture. Together they mean a picture of the whole thing which is what a holograph seems to be--a three-dimensional picture. For example, a photograph taken of a tank shows the tree in two dimensions--height and width, but not depth (figure 2-18).

(1) Laser light takes the picture in holography. There is a mirror behind the tree which reflects the laser light toward a piece of film. The developed film will have a record of the light waves which were reflected from the mirror combined with the light waves that were reflected from the tank.

(2) The film is called a hologram. When a laser beam hits the film, you will be able to see a three-dimensional image of the tank on the other side of the film (figure 2-19). The reason you see a three-dimensional image is because you are seeing the same light reflections you would see if you were looking at the tank itself (figure 2-20).



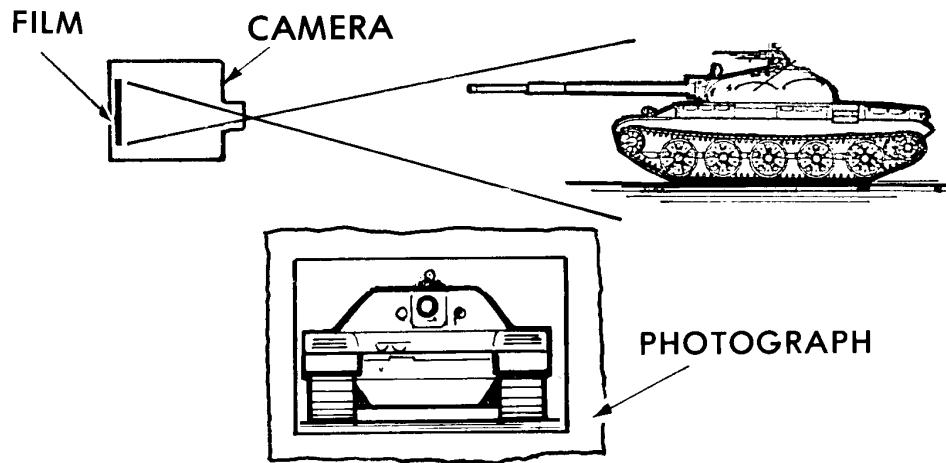

Figure 2-18. Two-dimensional photograph.

(3) Holograms are used in companies for three-dimensional advertising and by engineers looking for hidden wear and vibration in moving machine parts. A person can have a holographic portrait taken, and there is a video game with a three-dimensional gunfighter.

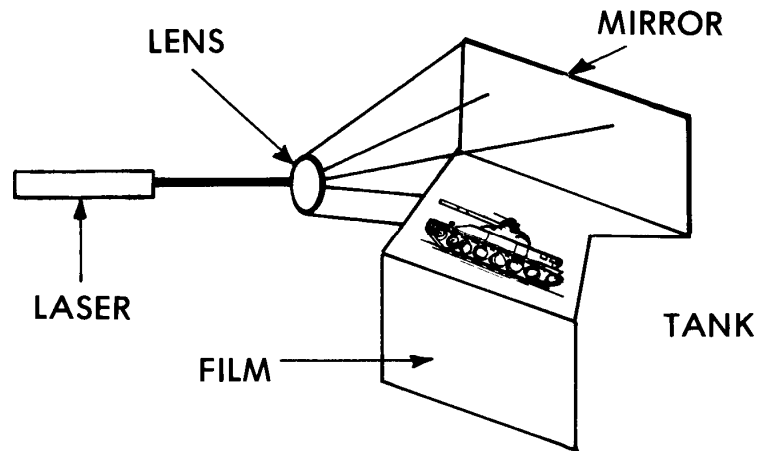

Figure 2-19. Holograph by laser beam.

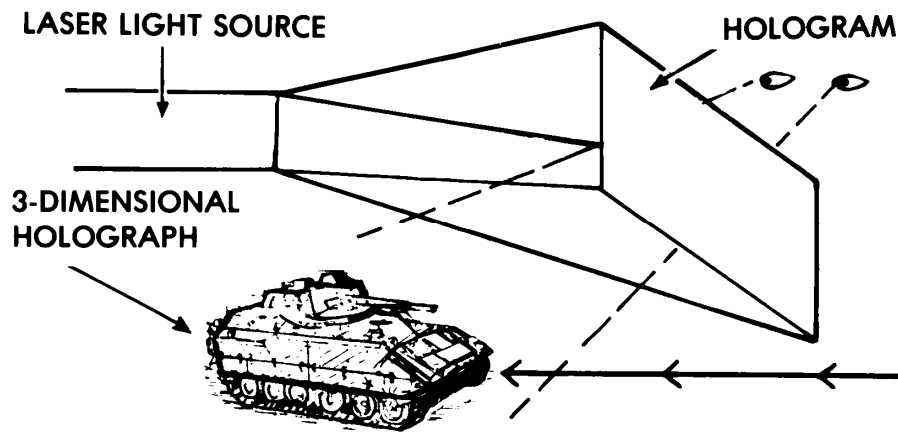

Figure 2-20. Holograph.

## 2-14. CHARACTERISTICS

a. **General.** Lasers have three important qualities which make laser light very special: intensity (brightness), directionality, and coherence.

(1) Intensity (Brightness). An ordinary light bulb generates and releases photons when the filament is excited (the bulb is turned on). A laser, on the other hand, stores the photons, building up pressurized light energy. When the photons are finally released there are so many more than a light bulb could possibly release in the same amount of time, that the resulting beam of light is very bright and very intense. A laser beam has greater intensity than any other light source. See figure 2-21.

(2) Directionality. A laser can be thought of as a kind of light gun which aims photons along the laser rod and fires them out one end like bullets. The tightly packed photons all go the same way as they leave the laser rod; the photons do not scatter or spread out the way ordinary light does. Regardless how far the laser light travels, it keeps going in exactly the same direction spreading very little; a laser beam is said to be highly directional. See figure 2-21.

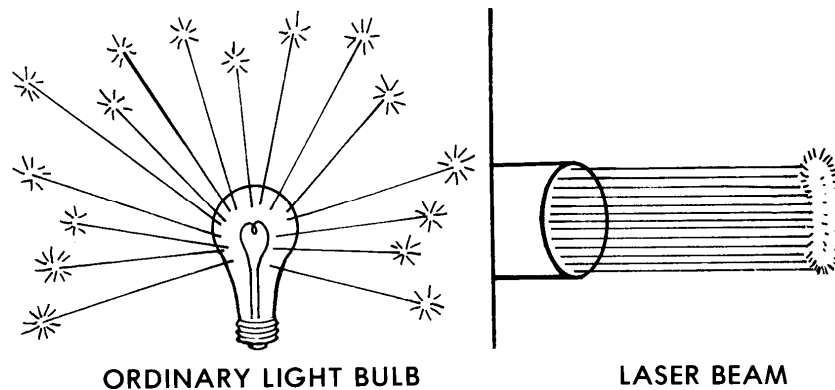

Figure 2-21. Intensity and directionality.

(3) Coherence. Like a unit of soldiers marching in review, the photons in laser light are all lined up together, evenly spaced, and exactly in step. Think of the members of an Army unit marching in review. They come on the field, each soldier marching in the same direction and at the same speed (figure 2-22). Photons in laser light move the same way--all lined up together, evenly spaced, and exactly in step. In other words, the photons are well-organized, meaning coherent. See figure 2-23.

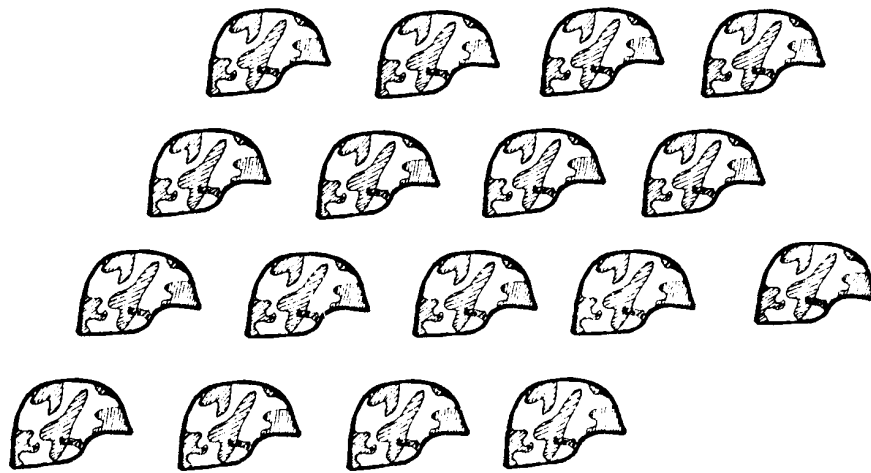

Figure 2-22. Coherence.

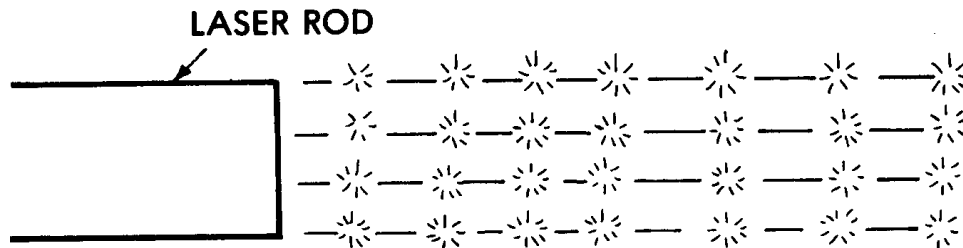

Figure 2-23. Laser coherence.

b. **The Laser System.** The basic concept in the laser system is that light energy under pressure is stored in the laser; that energy is released in a huge, high-powered burst of light which is a laser beam.

(1) Here is a good way to understand the laser system. Look at the following example.

(a) Imagine a cardboard tube into which you have put small, round, light-weight rocks. Put a thin piece of rubber on either end of the tube; hold the rubber in place with rubber bands (figure 2-24).

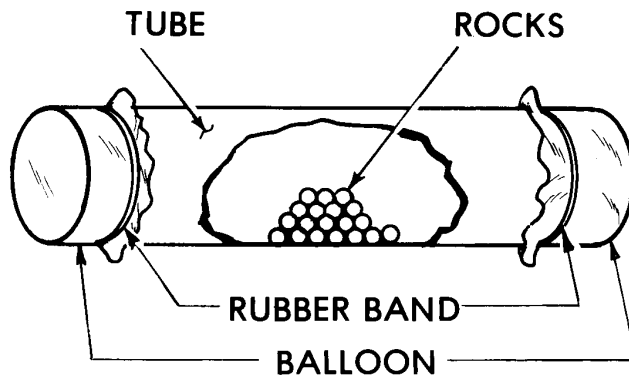

Figure 2-24. Sealed tube.

(b) Shake the tube slowly from end to end, and the rocks will slide from one end to the other (figure 2-25).

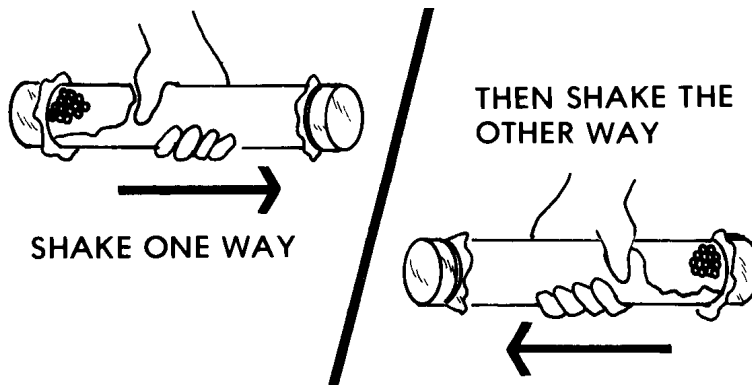

Figure 2-25. Shaking the tube.

(c) Shake the tube harder and faster so that you pump more energy into the rocks. The energy level of the rocks grows as they bounce off the rubber at either end of the tube (figure 2-26).

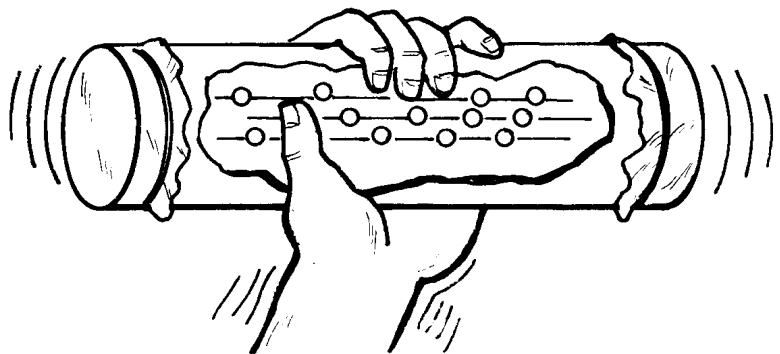

Figure 2-26. Shaking the tube vigorously.

(d) These rocks are so light they will not go through the rubber. Glue the rocks together, and make one piece of rubber thinner. Continue shaking the tube, and the rocks will burst through the weaker rubber (figure 2-27). In much the same way, a laser beam bursts forth from a laser.

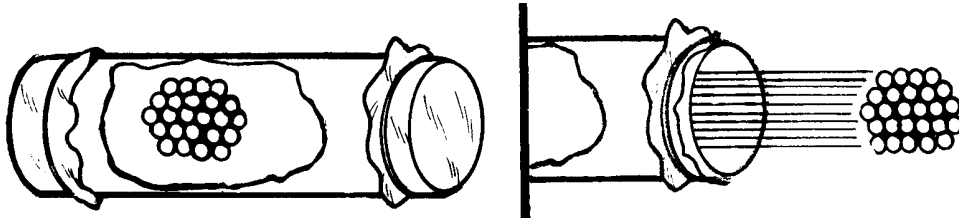

Figure 2-27. Contents escaping from tube.

(2) The laser system works in much the same way as the example of the rocks in a cardboard tube. Remember that example and relate it to this basic laser.

(a) The laser rod. The part of the system similar to the cardboard tube is called a laser rod. Some laser rods are solid and made out of glass-like materials called crystals. Other types of lasers use hollow glass tubes filled with mixtures of liquids or gases.

(b) The light source. A very bright light from a flash lamp is the light source for solid rod lasers. The flash lamp works like a camera flashbulb, but it can be used over and over.

(c) The power supply. The flash of light, the power supply, excites the atoms in the rod giving each atom extra energy. The atom has to do something with this extra energy in order to return to normal, so it throws off the extra energy as a small bundle of light--a photon.

(d) Chain reaction/stimulated emission. The flash of light excites some of the atoms causing them to throw off photons. Those photons bump into other atoms, exciting them and causing them to throw off photons.

(e) The reflecting box. The photons must be made to move along the center of the laser rod. To do this, put the rod inside a highly polished container called a reflecting box. The photons will bounce off the inside of the container and land on the laser rod.

(f) Mirrors. Put a mirror on either end of the reflecting box, one of the mirrors being strong and the other weak.

(g) The laser beam. Eventually, the stored up photons will burst forth through the end of the box with the weaker mirror, and this burst will be a beam of light--a laser beam.

(h) Pulsed laser. In this type of laser, the beam of light bursts forth quickly but lasts only a short time. Therefore, the flash lamp must be set off again to create another beam. This pattern of setting off the flash lamp again and again is a pattern like the human heart--pump, rest, then pump again. For that reason, this type of laser is called a pulsed laser. The other type of laser beam is a continuous laser beam.

(i) Color. Laser light waves are monochromatic; that is, they are of a single color. Actually, no light source is capable of producing light that is perfectly only one color, but laser can produce such a light more closely than any other system.

(j) Laser beam strength. The strength of the laser beam varies, depending on the type of laser system used. See figure 2-28.

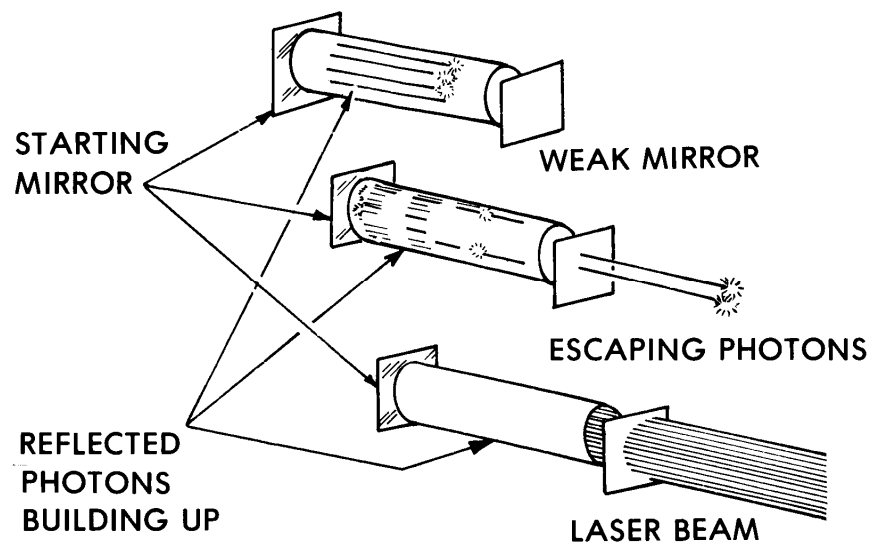

Figure 2-28. Laser beam strength.

## 2-15. BIOLOGICAL EFFECTS

Laser radiation should not be confused with ionizing radiation (radiation such as X-rays and gamma rays produce a change in neutral atoms or molecules). The biologic effects of laser radiation are essentially those of visible, ultraviolet, or infrared radiation upon tissues. Radiant intensities typically produced by lasers are as strong as the radiation previously only produced by the sun, nuclear weapons, burning magnesium, or arc lights. This is one of the important properties that make lasers potentially hazardous. Laser radiation which hits biologic tissue will be reflected, transmitted, and/or absorbed. The degree to which each of these effects takes place depends on the various properties of the tissue involved. For example, laser radiation is more readily absorbed by darker pigmented tissue and the dark brown or black pigment found in the skin, hair, and retina.

a. **Skin Effects.** Adverse effects from laser radiation vary depending on the exposure dose rate (amount of energy) transferred, and the conduction of heat away from the absorption site. Overirradiation from lasers can have the following ill effects on the skin.

(1) Erythema. Erythema of the skin is an abnormal redness caused from damaged or killed cells. This coloration may be temporary or last for years.

(2) Surface charring. The surface of the skin looks as though it has been burned.

(3) Deep tissue damage. The body cells for several layers have been damaged.

b. **Ocular Effects.** It is particularly important to wear protective goggles when working with lasers. There is a potential for eye damage from laser radiation.

(1) Retina damage. Blood vessels on and behind the retina may be damaged by lasers. Such damage causes these blood vessels to bleed and may result in partial or complete, temporary or permanent blindness. Another portion of the retina which may sustain damage from lasers is the retina periphery, the area surrounding the fovea of the eye. Laser injuries to the retina periphery may result in problems with peripheral vision. The patient should be able to perform all fine visual tasks normally. After a period of time, even though this injury is permanent, the patient will adapt and become unaware that his peripheral vision is not perfect.

(2) Lens opacification. The lens of the eye becomes opaque so that the person cannot see through that eye.

(3) Keratitis. The cornea of the eye becomes inflamed.

(4) Pupillary accommodation. The potential for damage to the eye depends on pupillary accommodation (the ability of the eye to adjust for various distances) and whether or not the individual was working with lasers with the naked eye or viewing lasers through binoculars, periscope, etc.

(5) Hemorrhage. Additional damage to the eye may result from hemorrhage (bleeding), the retina pushing out into the vitreous portion of the eye, and loss of fluid in the vitreous portion of the eye (vitreous humor).

## 2-16. CONTROL MEASURES IN THE MILITARY

a. **Survey--Army Environmental Hygiene Agency.** The Army Environmental Hygiene Agency has established guidelines for laser use and checks periodically to see that the guidelines are being followed.

**b. Medical Surveillance.** Personnel with a significant risk of exposure to hazardous levels of laser radiation shall have a preplacement and a termination eye surveillance examination. Such personnel will be included in an Occupational Vision Program for a vision screen examination every other year. Ocular (eye) surveillance is discussed below.

(1) Eye tests. Individuals routinely using Class 3 or Class 4 lasers in any research, development, testing, and evaluation (RDTE) effort where adequate protective measures are not feasible should be tested. Those people who are involved in only one laser test of short duration would not normally receive preplacement or termination eye examinations. They would be examined only if an injury caused by laser radiation was suspected.

(2) Hazardous laser equipment. Certain laser equipment, such as tripod-mounted, hand-held or airborne laser range finders, designators, or illuminators may be determined to be of sufficient hazard to operators and related personnel that the Surgeon General may require such persons to be examined. The warning page of the operator's and maintenance manuals for each laser device shall indicate which types of user or related personnel should be examined. Operators of currently fielded tactical laser systems are not required to receive this eye examination.

(3) Eye tests for maintenance personnel. Maintenance personnel routinely working with high intensity search lights or laser range finders, illuminators, and designators must have periodic examination for laser radiation.

(4) More tests. Operators and maintenance personnel routinely working with Class 3 engineering laser transits, geodimeters, and alignments must also have periodic examination for laser radiation.

(5) Visitors. Visitors must be adequately protected from the laser beam by protective devices. The visitors should not receive eye surveillance unless injury is suspected.

(6) Examination requirements.

(a) Preplacement and termination examinations. The preplacement ocular (eye) surveillance examination must be performed before a person is assigned to duties involving a significant risk of exposure to hazardous levels of laser. A termination examination must be completed as soon as practical when an individual ends his duties with laser sources.

(b) Periodic examinations. Laser personnel should be included in an occupational vision program. They should receive vision screening examinations every two years.



(c) Examination procedures. The ocular surveillance examination should be performed by an ophthalmologist, optometrist, or doctor skilled in funduscopy (examining the interior of the eyeball) and biomicroscopy (inspection of the cornea or lens by means of a slit lamp and corneal microscope combination). The examination includes the following.

1 An ocular history with special emphasis on photosensitizing drugs (drugs causing very high sensitivity to sunlight or ultraviolet rays); unusual sensitivity to sunlight; or lens surgery.

2 Visual acuity (clearness of vision) of each eye (far and near). If this is less than 20/20, determine what the visual acuity of each eye is.

3 Examination of the retina with the pupil dilated.

4 A slit lamp (biomicroscopic) examination of the cornea and lens with the pupil dilated.

5 Amsler grid testing of each eye.

6 A careful description, drawing, or photograph of any abnormality. The results of these examinations should be properly recorded in the patient's medical record.

(d) Accident examinations. If there is suspected or confirmed exposure of the eye to excessive levels of laser radiation, the individual must have an immediate (within 24 hours of exposure) ocular examination by an ophthalmologist or optometrist. This examination should include procedures for preplacement and termination ocular surveillance examinations, as well as other tests deemed necessary by the examining specialist.

(e) Accident reporting procedures.

1 Generally, follow laser accident reporting procedures listed in AR 40-400, chapter 6, and AR 385-40, paragraph 9-2.

2 Within 5 working days of the suspected or confirmed incident, file the Special Telegraphic Report of Selected Diseases, RCS MED-16. File this report of the exposure to radiation in excess of levels set in AR 40-46, Control of Health hazards from Lasers and Other high Intensity Optical Sources, chapter 2.

3 Within 72 hours after the accident, it must be reported according to local standing operating procedure.

### c. **Safety Procedures/Equipment.**

(1) Laser Range Safety Officer (LRSO). The Laser Range Safety Officer is responsible for ensuring that the Army Environmental Hygiene Agency guidelines for precautions around laser equipment are being followed.

(a) Class 2 lasers are terminated at the end of the useful beam and are not directed at personnel.

(b) When Class 3 and 4 lasers are in use, unprotected personnel must be excluded from the beam path where exposure limits are exceeded.

(c) Tracking of nontarget aircraft or vehicles is prohibited and the limits of the range are enforced.

(d) Objects or elements that could reflect laser beams must be removed. These include standing water, ice, and glass, but not snow. Snow simply diffuses the beam and is not hazardous.

(2) Range limitations. The amount of power and the proper distance from laser equipment must be maintained.

(3) Safety goggles. Personnel must wear the correct set of goggles for the optical density of the laser system being used. It must be remembered that one set of goggles will not protect a person from the hazards of every laser system.

## **2-17. SYMPTOMS OF LASER INJURY**

A reduction in the clearness of vision and pain are the main symptoms of laser injury. It may not be known that lasers are in use; therefore, medical personnel should suspect that a soldier has been exposed to lasers if he reports seeing bright flashes of light, he experiences eye discomfort and poor vision, and he has a feeling of unexplained heat. Obvious lesions such as corneal burns, retinal injury, retinal hemorrhage, and skin burns make the diagnosis of injury from lasers more certain.

## **2-18. FIRST AID FOR LASER INJURIES**

First aid for laser injuries begins with the aidman. In the division, management is limited to first aid only. Damage to the eye will be the most likely laser injury. Here is the procedure to deal with eye injury:

- a. Early identification of injury to the eye is important.
- b. Tell the patient not to squeeze his eyelids.

- c. Apply a binocular patch (no direct pressure) or a battle dressing around the head (the eyes will be covered).
- d. Evacuate the patient in the supine position.
- e. Administer systemic analgesics for moderate to severe pain.

## **2-19. SAFETY PRINCIPLES**

Some precautions must be used when handling or being near laser equipment.

- a. Never look into the beam of any laser.
- b. Remember that reflections of laser beams from polished surfaces are as dangerous as the beam itself.
- c. Do not point a laser at anyone.
- d. Be aware of the path of a laser beam whether you are handling a laser or someone else is handling a laser. Stay out of the laser beam path.
- e. Low energy infrared lasers can injure the eyes. Ordinary glass or plastic lenses or visors will protect the eye from far-infrared laser radiation such as carbon dioxide laser radiation. Exposure to laser radiation requires line of sight; therefore, concealment, cover, or avoiding looking at a known or suspected laser threat is very effective in preventing injury. DO NOT look at a laser light.
- f. The best eye protection from lasers is the protective eyewear made for this purpose. If such eyewear is lost or damaged, use any protective gear that is available. Ordinary eyeglasses or sunglasses will afford a very limited amount of protection. Even squinting can limit the amount of laser energy that enters the eye.
- g. Protect your skin. If hands or other parts of the body must be exposed to potentially hazardous levels of laser radiation, use protective coverings, gloves, or shields. Turn your face away from the target area. Shield laser welding and cutting facilities to prevent people not involved from looking at what is happening.
- h. Have periodic eye examinations because certain laser devices can cause damage to the eye.
- i. Be familiar with safety precautions for any laser device you are around, and stay a safe distance away (as recommended).

**Continue with Exercises**

## EXERCISES, LESSON 2

**INSTRUCTIONS.** The following exercises are to be answered by marking the response that best answers the question or best completes the incomplete statement or by writing the answer in the space provided.

After you have completed all the exercises, turn to the solutions at the end of the lesson and check your answers. For each exercise answered incorrectly, reread the material referenced after the solution.

1. An alpha particle has a low velocity, weak penetrating power, causes no disruption to the body's ion balance, and can be stopped by \_\_\_\_\_ or \_\_\_\_\_.
2. A beta particle corresponds to an electron of an atom, carries a negative charge, is faster and slightly more penetrating than an alpha particle, and can be stopped by \_\_\_\_\_.
3. A beta particle is unlikely to cause damage unless taken into the body through \_\_\_\_\_, \_\_\_\_\_, or \_\_\_\_\_.
4. Gamma rays are waves of energy with the speed of \_\_\_\_\_. Gamma rays have a high penetration power into the body and can cause body damage leading to \_\_\_\_\_.
5. Two basic sources of natural background radiation in the environment are cosmic radiation and \_\_\_\_\_.
6. Radioactive materials in the earth's crust are examples of \_\_\_\_\_ radiation.

7. Two kinds of medical radiation are diagnostic x-ray radiation and \_\_\_\_\_ radiation.
8. Industrial radiation includes the use of radiation in testing new \_\_\_\_\_.
9. List two characteristics of ionizing radiation.
  - a. \_\_\_\_\_.
  - b. \_\_\_\_\_.
10. Excessive radiation can cause body cells to react abnormally, thereby causing leukemia, or cancer of \_\_\_\_\_ or \_\_\_\_\_ which may not show up until years after the radiation.
11. The two major effects of radiation dealing with genetic mutations are permanent, transmissible changes in a gene function and \_\_\_\_\_ breakage.
12. The degree of damage from radiation done to a developing embryo or fetus depends on \_\_\_\_\_.
13. List three ionizing radiation control measures used in the military.
  - a. \_\_\_\_\_.
  - b. \_\_\_\_\_.
  - c. \_\_\_\_\_.

14. List three ways to reduce your exposure to ionizing radiation.
- a. \_\_\_\_\_.
  - b. \_\_\_\_\_.
  - c. \_\_\_\_\_.
15. The total radiation of wavelengths is called the \_\_\_\_\_.
16. Microwaves, part of the electromagnetic spectrum, are very short \_\_\_\_\_  
\_\_\_\_\_.
17. List three sources of microwave radiation (sources listed in this lesson).
- a. \_\_\_\_\_.
  - b. \_\_\_\_\_.
  - c. \_\_\_\_\_.
18. Microwaves are invisible and travel in an \_\_\_\_\_ and \_\_\_\_\_ movement.
19. Microwave radiation does not cause ionization; that is, microwaves do not cause atoms to \_\_\_\_\_.
20. Microwaves travel in straight lines and are reflected, \_\_\_\_\_, or  
\_\_\_\_\_.

21. List four general control measures for microwave radiation.
- a. \_\_\_\_\_.
  - b. \_\_\_\_\_.
  - c. \_\_\_\_\_.
  - d. \_\_\_\_\_.
22. The first letter of five words is combined to make up the word LASER. List those five words.
- a. L\_\_\_\_\_
  - b. A\_\_\_\_\_
  - c. S\_\_\_\_\_
  - d. E\_\_\_\_\_
  - e. R\_\_\_\_\_
23. Fundamentally, a laser is \_\_\_\_\_ energy stored under pressure; when the pressure becomes strong enough, the energy bursts forth in a \_\_\_\_\_.
24. List three uses of laser radiation discussed in this lesson.
- a. \_\_\_\_\_.
  - b. \_\_\_\_\_.
  - c. \_\_\_\_\_.
25. Two laser devices are being used more and more in the U.S.; these devices are the Point of Sale device used by the checker at the supermarket and the \_\_\_\_\_ system.

26. \_\_\_\_\_ is the name for the very bright light produced by a laser.
27. A laser beam keeps going in the same direction without spreading out very much; this quality is called \_\_\_\_\_.
28. The photons in a laser move in the same way--all lined up together, evenly spaced, etc.; this is called \_\_\_\_\_.
29. In order to excite the atoms to throw off photons to make laser light, a light source is sometimes used as the \_\_\_\_\_ supply.
30. Depending on the particular need, a laser rod can be made of something solid, or a \_\_\_\_\_.
31. How many colors does a laser have? \_\_\_\_\_.
32. There are two basic types of laser waves: continuous and \_\_\_\_\_.
33. Laser radiation can damage the skin. List three types of skin damage that laser radiation can cause.
- a. \_\_\_\_\_.
  - b. \_\_\_\_\_.
  - c. \_\_\_\_\_.
34. An individual who does not wear protective goggles when working with lasers may suffer damage to the eyes to include \_\_\_\_\_, lens \_\_\_\_\_, and \_\_\_\_\_ cornea.



35. List two control measures used by the Army to protect personnel against harmful laser radiation.

a. \_\_\_\_\_.

b. \_\_\_\_\_.

36. A soldier has an eye injury caused by laser radiation and is in moderate pain. List four things you should do.

a. \_\_\_\_\_.

b. \_\_\_\_\_.

c. \_\_\_\_\_.

d. \_\_\_\_\_.

37. List four safety principles you should remember when you work around lasers.

a. \_\_\_\_\_.

b. \_\_\_\_\_.

c. \_\_\_\_\_.

d. \_\_\_\_\_.

**Check Your Answers on Next Page**

## SOLUTIONS TO EXERCISES, LESSON 2

1. A sheet of paper or skin. (para 2-2b(1))
2. Heavy clothing. (para 2-2b(2))
3. The nose, the mouth, or an open wound. (para 2-2b(2))
4. Light.  
Gene mutations. (para 2-2b(3))
5. Terrestrial radiation. (para 2-3a(2))
6. Terrestrial. (para 2-3a(2))
7. Therapeutic. (para 2-3b(1))
8. Products. (para 2-3b(2))
9. You are correct if you listed any two of the following:

Radiation travels with a speed either equal to, or almost equal, to the speed of light.

The ability of radiation to penetrate the human body ranges from very little (less than 1/1000th for alpha particles) to deep penetration (gamma rays).

This radiation travels in straight lines with some scattering.

Some types of ionizing radiation are very well absorbed by air--(examples--alpha, beta, and neutrons); other types are not absorbed by air (example--gamma rays).

(para 2-4)

10. Skin or bones. (para 2-5a)
11. Chromosome. (para 2-5b)
12. The gestation stage at which the radiation occurs. (para 2-5c)
13. You are correct if you listed any three of the following:

Maintain inventories.

Survey leakage or exposure to radioactive sources.

Enforcement of SOPs on radiation.

Physical.

Bioassay for radioisotopes.

Film badge program.

(paras 2-6a(1) through (3), 2-6b(1) through (3))

14. Keep exposure TIME as short as possible. (para 2-6c(1))  
Move as great a DISTANCE away as possible. (para 2-6c(2))  
Wear appropriate SHIELDING for the type of radiation you are exposed to.  
(para 2-6c(3))
15. Electromagnetic spectrum. (para 2-7)
16. Radio waves. (para 2-7)
17. You are correct if you listed any three of the following:  
  
Microwave ovens.  
Microwave autoclave.  
Diathermy machine.  
Commercial machine to dry potato chips, glue binds, or photographic film.  
Machines to do biological research.  
Radar.  
Microwave spectroscopy.  
(paras 2-8a(1) through (3); 2-8b(1), (2); 2-8c; 2-8d)
18. Up and down. (para 2-9a)
19. Separate or change into ions. (para 2-9b)
20. Transmitted, or absorbed. (para 2-9c)
21. Inspection.  
Survey--detection equipment.  
Medical surveillance.  
Access control. (paras 2-10a through c)
22. a. Light.  
b. Amplification by.  
c. Stimulated.  
d. Emission of.  
e. Radiation. (para 2-12a)
23. Light. Laser beam. (para 2-12g)

24. You are correct if you listed any of these uses

Point of sale devices.  
Videodisc systems.  
Guidance devices for range finding.  
Tracking flying aircraft.  
Battleground simulation on land.  
Project lethal laser beams at a target, destroying the target.  
Security surveillance systems.  
Range finders.  
Communications.  
Medicine.  
Measuring the environment.  
Air turbulence studies.  
Holography.  
(para 2-13)

25. Videodisc. (para 2-13b)

26. Intensity. (para 2-14a(1))

27. Directionality. (para 2-14a(2))

28. Coherence. (para 2-14a(3))

29. Power. (para 2-14b(2)(c))

30. Hollow glass tube. (para 2-14b(2)(a))

31. One color. (para 2-14b(2)(i))

32. Pulsed. (para 2-14b(2)(h))

33. Erythema. (para 2-15a(1))  
Surface charring. (para 2-15a(2))  
Deep tissue damage. (para 2-15a(3))

34. Retinal damage, opacification, and inflamed. (paras 2-15b(1) through (3))

35. You are correct if you listed any two of the following:

Survey by the Army Environmental Hygiene Agency  
Medical surveillance  
Safety procedures  
Safety equipment (paras 2-16a,b,c)

36. Tell the soldier not to squeeze his eyelids.  
Apply a binocular patch or battle dressing so that the injured eye is covered.  
Evacuate the soldier in the supine position.  
Administer analgesics for pain. (paras 2-18b through e)
37. You are correct if you listed any four of the following:
- Never look into the beam of a laser.
  - Remember laser beam reflections from polished surfaces are as dangerous as the beam itself.
  - Do not point a laser at anyone.
  - Be aware of the path of any laser--one you are working with or one someone else is working with--and stay out of the laser beam.
  - Be properly protected around laser devices; wear eye goggles, electrical shielding, etc.
  - Have periodic eye examinations if you work with or around lasers.
  - Be familiar with safety precautions for any laser device you work around and follow those precautions. (para 2-19a through g)

**End of Lesson 2**

## LESSON ASSIGNMENT

### LESSON 3

Drowning and Near Drowning.

### LESSON ASSIGNMENT

Paragraphs 3-1 through 3-14.

### LESSON OBJECTIVES

After completing this lesson, you should be able to:

- 3-1. Define the terms "drowning" and "near drowning" and identify the process of drowning/near drowning in general terms, in fresh water, in salt water, and in cold water.
- 3-2. Identify the complications of near drowning.
- 3-3. Identify the procedures for treatment and management when reaching the victim in the water and immediately after removing the victim from the water.
- 3-4. Identify the procedures for hospital treatment and management of the victim to include respiratory system treatment, cardiovascular support, cerebral support, and hospital stay for observation.

### SUGGESTION

After completing the assignment, complete the exercises at the end of this lesson. These exercises will help you to achieve the lesson objectives.

## LESSON 3

### DROWNING AND NEAR DROWNING

#### Section I. GENERAL CONSIDERATIONS OF DROWNING AND NEAR DROWNING

##### 3-1. DEFINITION DROWNING/NEAR DROWNING

Drowning ranks as the fourth leading cause of accidental deaths in the United States, accounting for approximately 7,000 deaths annually. All ages are affected, but the greatest incidence is in the 20 to 29 year old age group. The terms "drown" and "near drowning" have a lethal connotation. The term "drown" means to suffocate under water. The term "near drowning," in this lesson, describes submersion in water from which an individual survives, at least temporarily.

##### 3-2. PROCESS OF DROWNING/NEAR DROWNING

In cases of drowning or near drowning, something goes wrong in the water--swallowing of water, fatigue, strong water currents, injury, cold, entanglement in kelp, loss of orientation, etc.--and the person panics, losing control of the situation. The following sequence of events may then take place.

- a. The victim goes underwater, further panics, and water enters his mouth and nose. He coughs and gasps, swallowing a great deal of water.
- b. The victim aspirates (inhales) a small amount of water into his larynx (area with vocal cords and trachea [windpipe]).
- c. This causes spasms of the laryngeal muscles (laryngospasms), thus sealing off the airway and protecting it, for the moment, from inhalation of more water.
- d. This airway obstruction eventually causes the victim to lose consciousness from hypoxemia (lack of oxygen in the blood).
- e. If the victim remains in the water, the laryngeal muscles relax as the asphyxia progresses. When the laryngeal muscles relax, water enters the lungs in massive quantities.
- f. What happens next depends on the type of water in which the incident takes place: fresh water, salt water, or cold water.

### 3-3. FRESH WATER DROWNING/NEAR DROWNING

If the drowning or near drowning occurs in fresh water and water enters the lungs, that water is quickly absorbed into the blood stream. Fresh water has a lower solute concentration than the plasma in the pulmonary capillaries; therefore, the fresh water is absorbed across the alveolar membrane into the bloodstream (figure 3-1).

a. Once in the bloodstream, this fresh water dilutes the blood and changes the blood chemistry. Fresh water also affects blood cells and tissue membranes causing hemolysis which is destruction of the blood cells.

b. The chemical change in the blood can result in cardiac dysrhythmias.

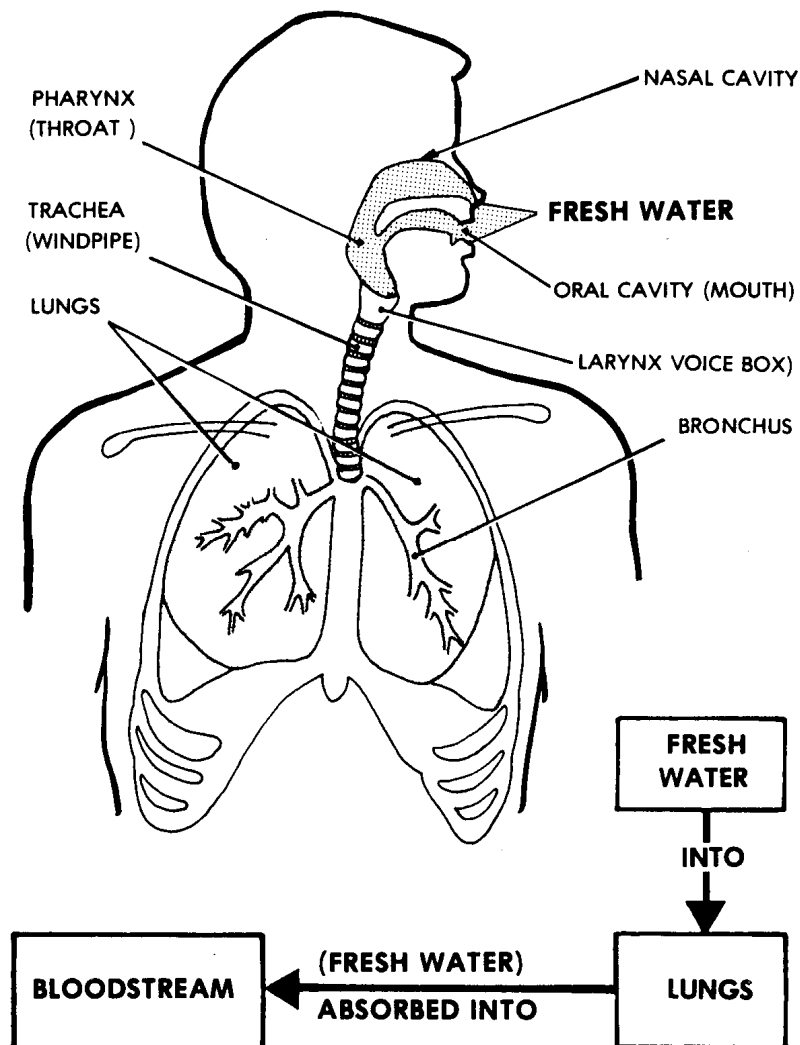

Figure 3-1. Fresh water drowning/near drowning.



### 3-4. SALT WATER DROWNING/NEAR DROWNING

The effect on the casualty is different when the incident occurs in salt water.

a. Salt water entering the lungs has a higher solute concentration than the plasma in the bloodstream. This causes fluid to be drawn out of the bloodstream into the lungs, causing a massive pulmonary edema (congestion of the lungs). The concentration of salt in the sea water draws the normal body water into the lungs (figure 3-2).

b. If enough fluid has been drawn out of the patient's bloodstream, the person may go into shock and drown in his own interstitial fluid (fluid bathing the cells).

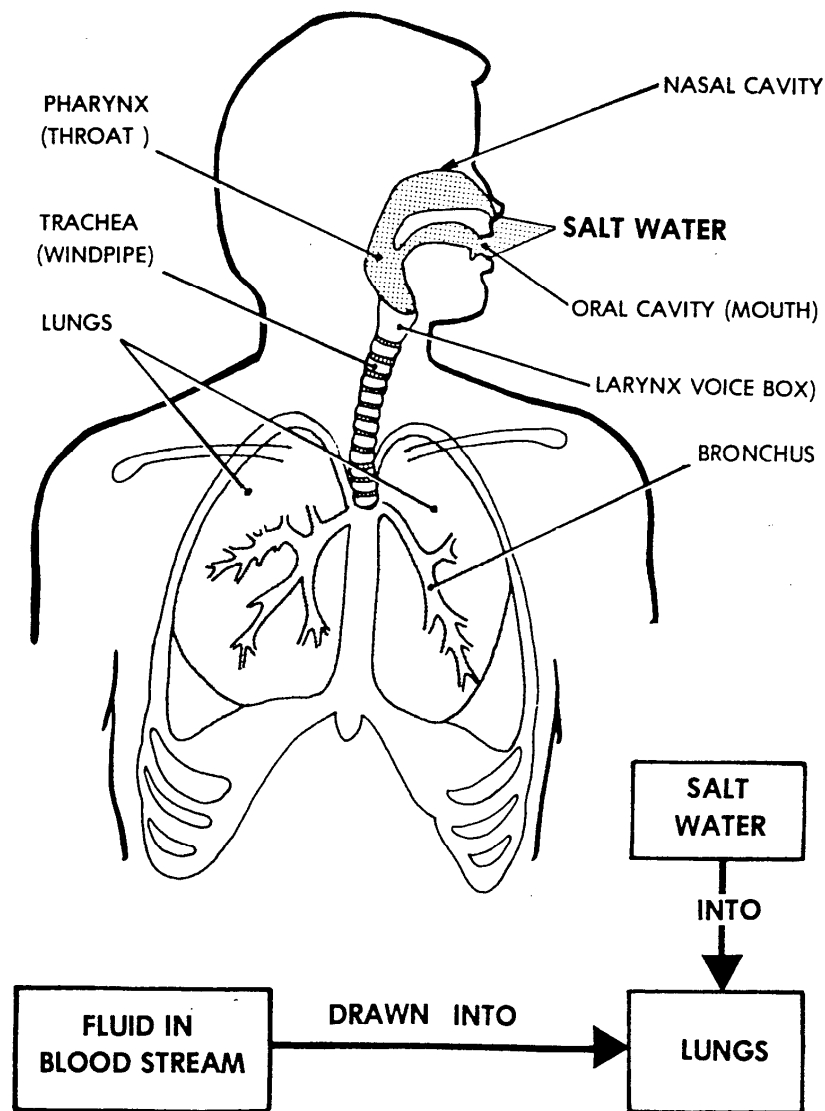

Figure 3-2. Salt water drowning/near drowning.

### **3-5. COLD WATER DROWNING/NEAR DROWNING**

a. **Hypothermia.** If the incident occurs in cold water, the victim's body temperature may drop below normal, usually between 78° and 90°F. This condition is termed hypothermia and can occur even in water that is not freezing. Since water conducts heat well and the person's body is usually warmer than the water, the water conducts heat from the individual to the surrounding water. As this conduction takes place, the person's body temperature drops and, at the same time, his body functions become slower. As his body temperature drops, his ability to think, act, and make rational judgments deteriorates. Eventually, he lapses into a coma and dies.

b. **The Diving Reflex.** The mammalian diving reflex, first identified in sea going animals, operates in cold water and extends the possible time of survival. This reflex, more active in younger persons, is a reaction of the body whereby the heartbeat slows and the peripheral arteries constrict, thus sending oxygenated blood away from the extremities and the intestines. Blood is sent, instead, to the vital organs--heart, brain, and kidneys. Survival time is extended because the rerouting of blood results in the body tissues needing less oxygen.

### **3-6. SUSPECTED INJURIES IN DROWNING/NEAR DROWNING**

If the incident occurred when the victim was diving or in shallow water, consider that he might have head, neck, or spine injuries. Treat the patient as if he had sustained a serious spine injury. Ask a conscious person if he can feel or move his toes. Also ask if he has tingling or less sensation in his arms, legs, or toes. If the person is face down, turn his body as a whole unit over so that he is on his back. If the person is unconscious, put him on a spine board and begin artificial ventilation as you move him to shore on the board. Secure him to the board before you move him out of the water.

## **Section II. ON-THE-SCENE TREATMENT/MANAGEMENT OF THE DROWNING/NEAR DROWNING VICTIM**

### **3-7. REACHING THE VICTIM IN THE WATER**

a. When you reach the victim in the water, establish an open airway and initiate artificial ventilation. Do this even before the victim is removed from the water.

b. Remove the victim from the water and continue artificial ventilation. If you suspect that the person may have a neck injury, remove him from the water on a long spineboard.

c. It is very important to begin artificial ventilation immediately. The longer a person goes without oxygen, the greater the chance of permanent neurological damage. Artificial ventilation can be done before the person is removed from the water. The rescuer can hold on to the side of a board or a dock and perform artificial ventilation at the same time. If full cardiopulmonary resuscitation (CPR) is needed, begin CPR as soon as the patient is stabilized on a long board.

### **3-8. AFTER REMOVING THE VICTIM FROM THE WATER**

a. Determine whether the person has a pulse. If there is no pulse, initiate CPR.

**NOTE:** Be sure to continue artificial ventilation or CPR until the victim has either revived or been pronounced dead by a physician. If there is no doctor at the scene, continue resuscitation efforts until the patient has been transported to an emergency facility.

b. Begin endotracheal intubation. This permits pressure ventilation and protects the airway from aspiration during the vomiting that is almost inevitable in resuscitation from near drowning.

c. Administer supplemental oxygen under positive pressure or in the highest possible concentration.

d. Suction as needed.

e. After an endotracheal tube is in place, you may insert a nasogastric tube to decompress the stomach.

f. If there is no pulse, begin advanced life support measures similar to those measures for cases of cardiopulmonary arrest.

(1) Establish an IV lifeline.

(2) Administer bicarbonate and epinephrine.

(3) Monitor the heart.

(4) Perform electric conversion of ventricular fibrillation.

**NOTE:** Often near drowning victims develop extreme metabolic acidosis. Whether or not the victim suffers cardiac arrest, he may need more bicarbonate than is usually given a cardiac arrest victim.

g. If the victim is hypothermic (rectal temperature below 84°F (28.9°C)), stabilize the body temperature by cutting away wet clothing and replacing it with dry clothing. DO NOT attempt to rewarm the victim in the field because these attempts may result in rewarming shock and may bring on cardiac arrhythmias (a variation from the normal rhythm of the heartbeat).

h. Transport the victim to the hospital as rapidly as possible, even if he seems to have recovered.

### **Section III. HOSPITAL TREATMENT/MANAGEMENT OF THE NEAR DROWNING VICTIM**

#### **3-9. RESPIRATORY SYSTEM TREATMENT**

a. The first priority in the hospital should be intensive pulmonary care with the goal of achieving adequate arterial blood-gas and acid-base levels. This can be achieved by administering oxygen to a spontaneously breathing patient. For a patient who is not breathing, keep an endotracheal tube inserted with a cuffed tube connected to a mechanical ventilator. Continue the sodium bicarbonate IV to restore the acid-base level to normalcy.

b. Follow these general treatment guidelines.

(1) Monitor the blood gases to determine how long to continue administering bicarbonate (being given by IV) and ventilatory support.

(2) In all cases, continue giving high supplemental levels of oxygen inhalation until the arterial blood-gas studies show that lower oxygen concentrations are required. When the oxygen in the arteries and the acid-base levels improve, the person usually regains consciousness.

(3) A chest x-ray should be taken to check for pneumonia or pulmonary edema (congestion of the pulmonary air spaces).

(4) If the victim is suffering from bronchospasms, administer a bronchodilator (an agent that causes expansion of the lumina of the air passages of the lungs) such as isoproterenol by inhalation or IV injection.

(5) If a near drowning victim is suffering from aspiration pneumonitis, administer antibiotics to combat the pneumonitis.

### **3-10. CARDIOVASCULAR SUPPORT**

a. Monitor the cardiac system because hypoxemia (inadequate oxygen in the blood), acidosis (disturbance in the acid-base balance of the body), and hypothermia (below normal body temperature) may cause cardiac dysrhythmias (abnormal rhythms in the heartbeat).

b. Monitor the central venous (veins) pressure.

(1) If the pressure is low, initiate an IV to replace the fluid volume. If the pressure remains low, you may consider administering dopamine.

(2) If the pressure is high:

(a) Restrict fluid restriction.

(b) Administer diuretics.

(c) Use vasodilators.

### **3-11. CEREBRAL SUPPORT**

If cerebral edema is confirmed, use osmolar agents--for example, mannitol.

### **3-12. HOSPITAL STAY FOR OBSERVATION**

a. **24 Hours.** A person who shows no signs or symptoms on the day of the incident should be hospitalized 24 hours for observation.

b. **48-72 Hours.** An individual who must be treated for particular signs or symptoms should be hospitalized for 48 to 72 hours, depending on the severity of the signs/symptoms.

### **3-13. POST-IMMERSION SYNDROME**

The following complications may occur up to three days after the episode.

a. Alteration of electrolytes (fresh water near drowning).

b. Acidosis.

c. Aspiration pneumonia.

d. Pulmonary edema.

- e. Atelectasis.
- f. Cardiac dysrhythmias.
- g. Cerebral edema.

### **3-14. NEVER GIVE UP HOPE**

A five-year-old Canadian boy was found totally immersed in water. He had been immersed for 30 minutes. He was unconscious and had no heart rate for five to ten minutes. His pupils were dilated, his skin was blue, and there were no respirations. Mouth-to-mouth resuscitation was started immediately and blankets were wrapped around him at the hospital. Rectal temperature at the hospital was 81°F. (Remember that your patient is not “dead until they are warm and dead.”) He was then immersed in a hot-water bath repeatedly for ten minutes at a time. He was intubated and given 100 percent oxygen. Initially, his color changed from cyanosis (blue) to mottled. The skin color improved soon due to the oxygen. After 1 1/2 hours, the boy's temperature had risen to 93.9°F and he was beginning to respond. The pulse was steady without arrhythmias. During the first 48 hours, he had neurologic defects. Coordination was poor and motor power in the extremities was poor. After three months, his muscular weakness slowly disappeared and he recovered completely.

**Continue with Exercises**

### EXERCISES, LESSON 3

**INSTRUCTIONS.** The following exercises are to be answered by marking the response that best answers the question or best completes the incomplete statement or by writing the answer in the space provided.

After you have completed all the exercises, turn to the solutions at the end of the lesson and check your answers. For each exercise answered incorrectly, reread the material referenced after the solution.

1. What is the meaning of the term "drown" in this lesson?

---

2. Define "near drowning" as the term is used in this lesson.

---

3. The sequence of events in a drowning or near drowning incident are as follows:

- a. The victim goes underwater; as water enters the person's mouth and nose, the victim begins to \_\_\_\_\_ and \_\_\_\_\_.

- b. The victim inhales a small amount of water into the \_\_\_\_\_ and \_\_\_\_\_; this causes spasms of the \_\_\_\_\_, sealing off the airway.

- c. The airway obstruction causes \_\_\_\_\_ (a lack of oxygen in the blood).

4. If the drowning/near drowning incident takes place in fresh water and the victim remains in the water, as the person loses consciousness, the laryngeal muscles relax allowing water into the lungs where it is absorbed into the \_\_\_\_\_.

5. In a fresh water drowning/near drowning, the fresh water in the victim's body causes \_\_\_\_\_ and changes in \_\_\_\_\_ chemistry which can cause \_\_\_\_\_.
6. In a salt water drowning/near drowning, fluid is drawn from the bloodstream into the \_\_\_\_\_ causing congestion of the \_\_\_\_\_, or the victim may go into shock and drown in his own \_\_\_\_\_.
7. If the incident takes place in cold water, two considerations not present in fresh or salt water drowning/near drowning are hypothermia and \_\_\_\_\_.
8. The condition of hypothermia means that \_\_\_\_\_  
\_\_\_\_\_.
9. The \_\_\_\_\_, first discovered in sea-going mammals, operates when the incident takes place in cold water. The victim's \_\_\_\_\_ slows and the arteries reroute the blood to the \_\_\_\_\_, \_\_\_\_\_, and \_\_\_\_\_. Survival time is extended because the blood rerouting results in \_\_\_\_\_  
\_\_\_\_\_.
10. If the incident occurred in shallow water or when the person was diving, consider that the victim may have \_\_\_\_\_ injuries.
11. List three complications which may occur up to three days after a near-drowning.
  - a. \_\_\_\_\_.
  - b. \_\_\_\_\_.
  - c. \_\_\_\_\_.



12. While the victim is still in the water, the first priority is to establish an \_\_\_\_\_ and begin artificial \_\_\_\_\_; do this before removing the person from the water.
13. If you suspect a neck injury, remove the victim from the water on a \_\_\_\_\_.
14. After you remove the victim from the water, check the victim's \_\_\_\_\_ and begin \_\_\_\_\_ if necessary.
15. If the person is hypothermic, stabilize the body temperature but DO NOT attempt to rewarm. There is a danger in causing \_\_\_\_\_ or \_\_\_\_\_.
16. Hospital treatment of the person includes treatment to restore blood-\_\_\_\_\_ and acid- \_\_\_\_\_ levels, a \_\_\_\_\_ to check for pneumonia or pulmonary edema, administering of a bronchodilator to stop \_\_\_\_\_, and giving \_\_\_\_\_ if the person is suffering from pneumonitis.
17. A person who shows no symptoms on the day of the incident should be hospitalized for \_\_\_\_\_ hours for observation.
18. A person who needs treatment for some symptoms should be hospitalized for \_\_\_\_\_ to \_\_\_\_\_ hours, depending on the severity of the symptoms.

**Check Your Answers on Next Page**

## SOLUTIONS TO EXERCISES, LESSON 3

1. Drown means to suffocate underwater. (para 3-1)
2. Near drowning means--submersion in water from which an individual survives, at least temporarily. (para 3-1)
3. a. Cough and gasp . (para 3-2a)  
b. Larynx and windpipe;.laryngeal muscles. (para 3-2b, 3-2c)  
c. Hypoxemia. (para 3-2d)
4. Bloodstream. (para 3-3)
5. Hemolysis. (para 3-3a)  
Blood. (para 3-3a)  
Cardiac dysrhythmias (para 3-3b)
6. Lungs. (para 3-4)  
Lungs. (para 3-4)  
Interstitial fluid. (para 3-4a)
7. The diving reflex. (para 3-5b)
8. The victim's body temperature drops below normal, usually 78° to 90°F.  
(para 3-5a)
9. Diving reflex.  
Heartbeat.  
Heart, brain, and kidneys.  
The body tissues needing less oxygen (para 3-5b).
10. Spinal. (para 3-6)
11. You are correct if you listed any three of the following:
  - . Alterations of electrolytes.
  - . Acidosis.
  - . Aspiration pneumonitis.
  - . Pulmonary edema.
  - . Atelectasis.
  - . Cardiac dysrhythmias.
  - . Cerebral edema. (para 3-13)

12. Airway.  
Ventilations. (para 3-7a)
13. Long spineboard. (para 3-7b)
14. Pulse.  
CPR. (para 3-8a)
15. Rewarming shock or cardiac arrhythmias. (para 3-8g)
16. Gas;.base. (para 3-9a)  
Chest x-ray. (para 3-9a(3))  
Bronchospasms. (para 3-9a(4))  
Antibiotics. (para 3-9a(5))
17. 24. (para 3-12a)
18. 48 to 72. (para 3-12b)

**End of Lesson 3**

## LESSON ASSIGNMENT

### LESSON 4

Heat Injuries.

### LESSON ASSIGNMENT

Paragraphs 4-1 through 4-29.

### LESSON OBJECTIVES

After completing this lesson, you should be able to:

- 4-1. Identify the characteristics/ general findings of heat injuries.
- 4-2. Identify the mechanisms for the regulation of temperature in the human body.
- 4-3. Identify heat transference mechanisms.
- 4-4. Identify factors which affect heat injuries.
- 4-5. Identify the causes, signs, and treatment for heat cramps.
- 4-6. Identify the causes, signs, and treatment for heat exhaustion.
- 4-7. Identify the causes, signs/ symptoms, and treatment for heatstroke.
- 4-8. Identify measures for prevention of heat injuries.

### SUGGESTION

After completing the assignment, complete the exercises at the end of this lesson. These exercises will help you to achieve the lesson objectives.

## LESSON 4

### HEAT INJURIES

#### Section I. CHARACTERISTICS/GENERAL FINDINGS OF HEAT INJURIES

##### 4-1. INTRODUCTION

The environmental conditions to which troops must adapt can vary greatly. Troops participating in maneuvers near the Soviet border may encounter the extremes of the Arctic cold while troops participating in maneuvers in the Middle East must adapt to the extremes of equatorial heat. An inability to adapt to environmental conditions can very often lead to heat and cold injuries. As a Medical NCO, you must know the preventive measures as well as the treatment for heat and cold injuries that result when troops do not adapt to their environment. In this lesson, information regarding heat injuries will be given.

##### 4-2. GENERAL

People engaged in outdoor activities are susceptible to illnesses from exposure to heat, especially in the warmer areas of the world as well as all parts of the world in the warmer periods of the year. Illnesses from exposure to heat are also seen in industries in which the environment is very hot. Often, overexposure to heat will occur when a person has just arrived in a very hot climate or in the early part of the year. In either case, the human body has not had the chance to adjust to the higher temperatures.

##### 4-3. CAUSE AND IMPORTANCE

a. When a person gets hot, his body perspires. The perspiration evaporates causing the body to cool. In addition to water, perspiration contains salt. Salt helps to regulate nerve impulses and muscle reactions. If the water and salt lost through perspiration are not replaced, heat injury can result. There may be peripheral vasodilation (external surface dilation of a vessel, especially dilation of arterioles leading to increased blood flow to a part); increased cardiac output (increased systolic pressure of 120 mm or higher, as high as 180 mm); and sweating. Sweating leads to dehydration resulting in circulatory instability. If the person remains erect and immobile, syncope (fainting) may result. Muscular activity, however, usually prevents fainting.

b. The three principle types of heat injury are heat cramps, heat exhaustion, and heatstroke. Heatstroke is also called sunstroke, heat pyrexia, and hyperthermia. Heat cramps and heat exhaustion will prevent a person from performing his mission effectively and can develop into heatstroke. Heatstroke is fatal if effective measures are not taken immediately.

## Section II. MECHANISMS FOR THE REGULATION OF TEMPERATURE IN THE HUMAN BODY

### 4-4. INTRODUCTION

Human beings, other mammals, and birds are homeothermic or warm-blooded which means that they are capable of maintaining a body temperature that is nearly constant. A human being's body temperature is maintained by very precise and complicated mechanisms. These mechanisms are dominated by a small sensory structure--the "human thermostat"--which is located in the front part of the hypothalamus of the brain. This human thermostat or temperature regulating center is sensitive to changes in temperature in the blood and peripheral receptors for warmth or cold in the skin. In order to maintain the constant temperature, body temperature is regulated in two ways: heat production and heat dissipation.

### 4-5. HEAT PRODUCTION

a. **Heat Produced by the Body.** Most of the heat produced by the body comes from oxidation of the food we eat. Metabolic rate is the term for the rate at which the heat is produced. The rate at which heat is produced depends on the following.

- (1) Muscular activity. Exercise increases heat production.
- (2) Glandular rate. The higher a person's metabolism rate the more heat produced.
- (3) Food intake. Some types of food such as foods containing sugar are burned up more quickly than other foods, thus producing more body heat.
- (4) External temperature. The body reacts to environmental temperature. If the temperature of the environment (air, water) is hot, the body reacts accordingly and becomes warmer.
- (5) Certain hormones. Certain hormones may increase a person's metabolic rate, thus increasing that person's heat production.

b. **Heat Produced by Tissues.** Tissues are responsible, in part, for heat production. Skeletal muscle tissue contractions produce heat and are an important part of the homeostatic mechanism for maintaining normal body temperature. During a skeletal muscular contraction, only 20 or 30 percent of the total energy released is used for mechanical work. The rest of the energy is released as heat. Two types of heat energy are produced: initial heat (produced by the contraction and relaxation of a muscle) and recovery heat (produced after relaxation of a muscle).

c. **Heat Distributed by the Blood.** Blood flow plays a role in the regulation of normal body temperature because blood contains a large volume of water (an excellent heat absorber and coolant).

#### 4-6. HEAT LOSS OUTLETS (HEAT DISSIPATION)

a. **Respiratory System/Skin.** When the body becomes warm--hot summer weather, strenuous exercise, etc.--, blood temperature becomes higher and activates the heat losing center (the hypothalamus). Impulses are sent to the sweat glands of the skin, and these sweat glands produce perspiration. Perspiration evaporates from the surface of the skin, and the skin is cooled. About 80 to 95 percent of body heat is lost through the skin.

b. **Urine/Feces.** Two ways in which the body maintains its almost constant normal temperature are through urination and elimination of feces.

#### 4-7. EXCESSIVE HEAT LOSS

The goal of the hypothalamic thermostat in the body is to maintain a constant body temperature. If your heat-losing mechanisms give off more heat than your heat-producing mechanisms, then your temperature falls. An artificial way to prevent too much heat loss is by wearing appropriate clothing. Clothing which is slightly loose creates a dead space which insulates the body. A natural means of preventing too much heat loss is the body's subcutaneous fat. Body fat conducts heat only one-fourth as rapidly as other tissues, thus conserving heat.

#### 4-8. BODY TEMPERATURE REGULATION MECHANISM

a. **Hypothalamus.** The hypothalamus is a small portion of the brain which controls many body activities, some of which are related to homeostasis (the condition in which the body's temperature remains about the same most of the time). The hypothalamus has two main centers: a center which controls heat production and a center which controls heat loss.

(1) Control of body heat production. When the body is exposed to internal or external temperatures above normal, the blood vessels expand. There is increased sweating, panting, and the body produces less heat.

(2) Control of body heat loss. If the body is exposed to low temperatures, the blood vessels shrink, the surface hair on the skin stands erect, and the person shivers. All of these responses slow down the loss of body heat.

b. **Body Reactions.**

(1) Hot skin.

(a) Vasodilation. Heat causes the blood vessels to dilate or expand, a process called vasodilation.

(b) Increased blood flow. Expanded blood vessels allow an increased blood flow which increases heat loss from the body. The individual becomes cooler.

(2) Cold skin. Impulses transmitted by the sympathetic nervous system slow down the body's organs. In the case of cold skin, blood vessels have constricted causing a decreased blood flow. The decreased blood flow means that less body heat is lost to the environment and the skin is cold.

### Section III. HEAT TRANSFERENCE MECHANISMS

#### 4-9. INTRODUCTION

The oxidation of the foods we eat produces body heat. The temperature of a person's body would rise and keep on rising if there was not a way to remove this body heat. The main ways of losing body heat are evaporation, radiation, conduction, and convection.

#### 4-10. EVAPORATION

Evaporation is the changing of a liquid to a vapor. Water must be heated to a high temperature to evaporate. The latent heat of evaporation is the amount of heat necessary to evaporate one gallon of water at 30°C (86°F). Because water has a high latent heat of evaporation, every gram of water evaporating from the skin takes with it a great deal of heat--about 0.58 calories/gram of water. The evaporation of only 150 ml of water per hour is enough to remove all the heat produced by the body under normal conditions.

a. Under extreme conditions, about four liters (one gallon) of perspiration is produced each hour. This volume can remove about 2,000 calories of heat from the body. This is approximately 32 times the normal level of heat production.

b. The rate of evaporation varies according to the relative humidity in the air. THE HIGHER THE RELATIVE HUMIDITY, THE LOWER THE RATE OF EVAPORATION (figure 4-1).

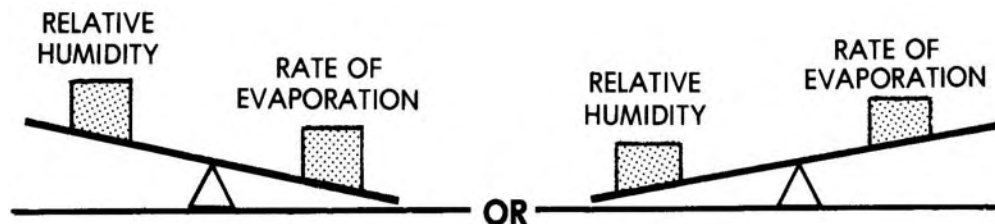

Figure 4-1. Rate of evaporation.



c. Evaporation in the form of sweating is a way the body can lose heat if the air temperature is greater than the person's body temperature.

d. Evaporation does not necessarily require sweating because there is a continuous spreading out of water molecules through the skin. About 20 to 25 percent of the body's normal heat production is lost by evaporation. Humans can increase this type of heat loss by sweating; animals increase this type of heat loss by panting and salivating.

#### 4-11. RADIATION

Radiation is the transfer of heat as infrared heat rays from one object to another without physical contact. The human body loses heat by the radiation of heat waves from the body to cooler objects nearby such as ceilings, floors, and walls. If these objects are at a higher temperature, a person's body absorbs the heat--also by the process of radiation. The temperature of the air has no relation to the radiation of heat to and from objects. That is why skiers can remove their shirts and be warm in bright sunshine even though the air temperature is low. The radiant heat from the sun warms them (figure 4-2).

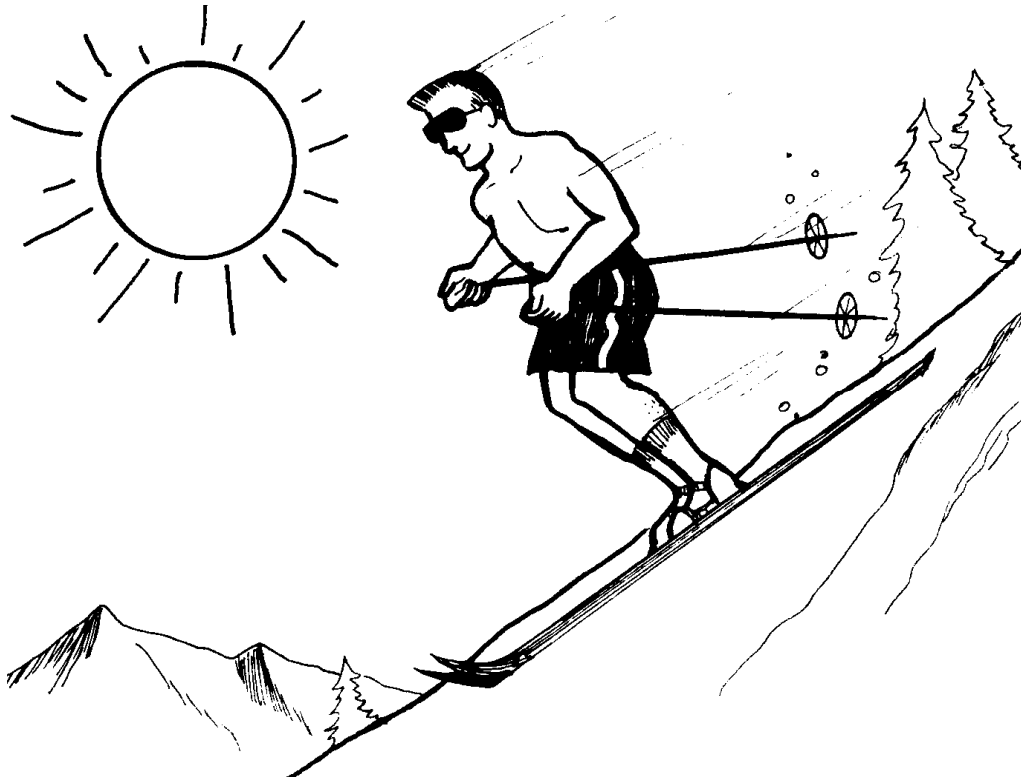

Figure 4-2. Radiation--heat from the sun.

## 4-12. CONDUCTION

Conduction is another method of heat transfer. In this process, body heat is transferred to a substance or object which is actually in contact with the human body-- for example, a chair, clothing, jewelry (figure 4-3). About three percent of body heat is lost by conduction.

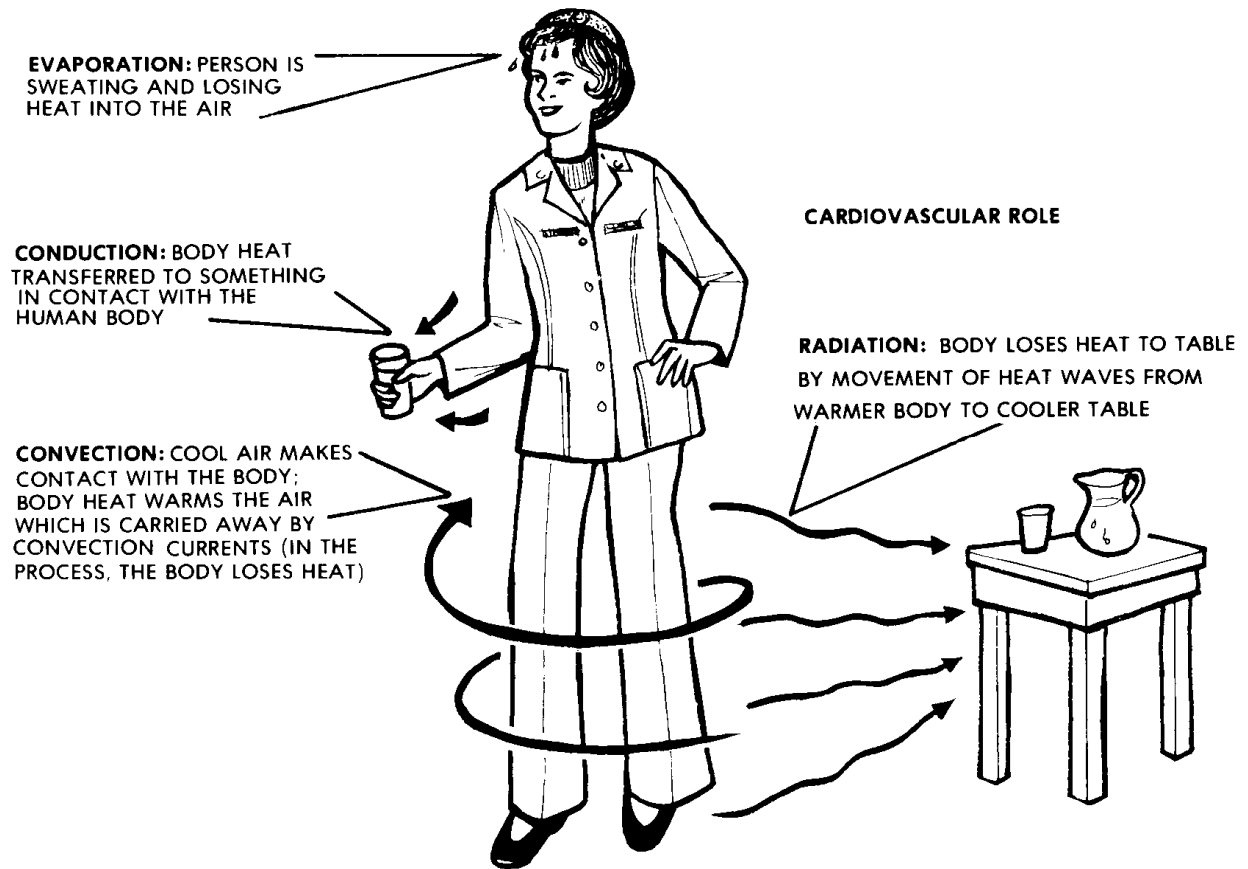

Figure 4-3. Conduction--heat to clothing.

### 4-13. CONVECTION

Convection is the transference of heat by air movement or body motion (figure 4-4). Cool air making contact with the body is warmed and carried away by convection currents. More cool air moves over and around the body and is carried away by convection currents again. The faster the air moves, the faster the rate of convection. A person loses about 15 percent of body heat into the air by this method of heat transfer.

### 4-14. CARDIOVASCULAR ROLE

Blood, one of the parts of the cardiovascular system, is a complex liquid that performs a number of critical functions. One of these functions is to aid in the regulation of normal body temperature. Blood contains a large volume of water and is, therefore, an excellent heat absorber and coolant.

a. Blood flow to the skin plays an important part in heat transference. When the temperature of the environment is low or a person's blood temperature falls below normal, impulses from the heat-promoting center of the body stimulate nerves that cause blood vessels of the skin to constrict (get smaller). This causes a decrease in the flow of warm blood from the body's internal organs to the skin. This reduction in heat helps raise the internal temperature of the body. Heat has been retained.

b. When stress, environment, or some other factor causes the body's temperature to be above normal, impulses stimulate the heat-losing center. Heat reducing mechanisms are set in motion. Blood vessels in the skin dilate (get bigger). More warm blood moves to the skin. The skin becomes warm, and the excess heat radiates out to the environment (figure 4-5). The slower metabolic rate helps bring the temperature of the body down to normal.

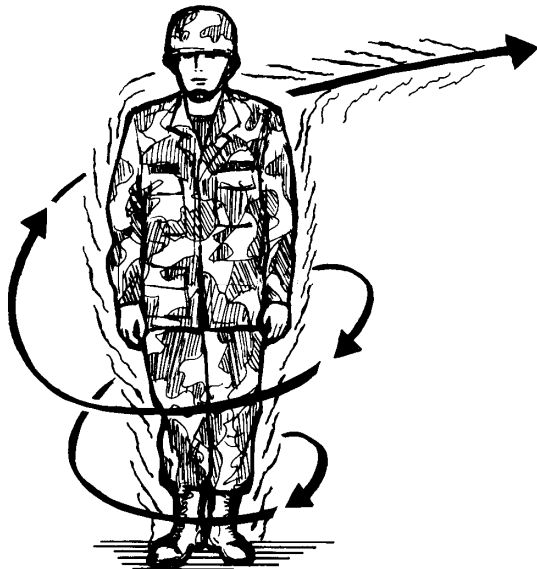

Figure 4-4. Convection--body heat to the air.

Figure 4-5. Heat transfer mechanisms.

## Section IV. FACTORS AFFECTING HEAT INJURIES

### 4-15. INTRODUCTION

The general physical condition of the individual has a significant bearing on a person's reaction to heat. A large number of conditions affect an individual's ability to withstand heat. These conditions include the following.

- a. **Infections.** Acute and chronic infections including the convalescent state.
- b. **Febrile Conditions.** The body temperature of a person with a fever is already above normal. Less heat is required to cause him to suffer from heat injury than if his temperature was normal.
- c. **Immunizations (Reactions).** Reactions to immunizations have been correlated with an increase in heat injuries, possibly due to associated fever.
- d. **Vascular Diseases.** An individual with poor blood circulation such as someone suffering from a peripheral arterial disease with its decreased blood flow is more susceptible to heat injury.
- e. **Diarrhea.** Abnormally frequent passages of loose stools constitute this condition.
- f. **Conditions Affecting Sweat Secretion.** For example, skin diseases which affect sweating affect ability to withstand heat.
- g. **Skin Trauma.** Heat rash and acute sunburn are examples.
- h. **Previous Heat Injury.** A person who has had heat exhaustion or heatstroke is predisposed to future attacks of heat injury.
- i. **Recent Use of Alcohol (24 Hours)/Drugs.**
  - (1) Alcohol dehydrates a person.
  - (2) Some drugs may compromise cardiac output, respiration, sweating, or increase the basal metabolism rate thus producing more heat. Other drugs inhibit sweating. Included are atropine, antihistamines, some tranquilizers, cold medicines, and some antidiarrheal medications.
- j. **Chronic Use of Diuretics.** This may affect reaction to heat.
- k. **Dehydration.** Heat affects a dehydrated person.

l. **Lack of Sleep.** This is a major factor predisposing to heat injury because the cardiovascular system (CVS), muscular, and possibly the central nervous system (CNS) are already compromised.

m. **Additional factors.**

- (1) Age--persons over 40 years old.
- (2) Poor personal hygiene.
- (3) Poor general health.

#### **4-16. GENERAL**

The risk of heat injury is much higher in overweight, unfit, persons than in those of normal weight. Therefore, special care must be taken when such persons are exposed to high temperatures. One attack of either heatstroke or severe heat exhaustion may predispose to a second. An individual once affected should be exposed to heat with caution. Predisposition is not developed in the case of heat cramps.

### **Section V. HEAT CRAMPS**

#### **4-17. DEFINITION/CHARACTERISTICS**

Heat cramps are painful cramps of the voluntary muscles, usually of the abdomen, legs, or arms. The cramps are caused by the inability of the muscles to relax once they have contracted. This inability to relax is caused by faulty nerve impulses to the muscles resulting from salt imbalance in the body. The condition occurs as a result of profuse sweating which removes water and sodium chloride from the body. Heat cramps normally result from excessive loss of salt after a person has been working in hot weather for a long period of time. The salt loss causes painful contractions of muscles; the muscle contractions are referred to as heat cramps. A person with heat cramps will recover if the salt and water imbalance in the body is corrected and steps are taken to prevent heat cramps from developing into more serious injuries.

#### **4-18. SIGNS/SYMPTOMS**

The most obvious indications of heat cramps are muscle cramps or spasms in the casualty's abdominal area and/or in his limbs. The casualty will usually grasp or massage the muscle that is having the spasm--if the spasm is in one of the limbs. If the spasm is in the person's abdominal region, the casualty may hold his abdomen and bend over at the waist. The casualty will normally be sweating profusely. His skin, however, will remain warm and his body temperature will be either normal or only slightly elevated. His blood pressure will be within his normal range.

## 4-19. TREATMENT

The treatment for heat cramps is to replace the salt and water lost from the body and to prevent the casualty from suffering additional heat injury (heat exhaustion or heatstroke).

- a. **Protect the Casualty from the Sun.** Move the casualty to a cool, shaded area to rest. If shade is not available, improvise using ponchos, blankets, or other available materials to protect him from direct sunlight. Have him sit or lie in a comfortable position.
- b. **Loosen Clothing.** Loosen tight-fitting clothing if you are not in a chemically-contaminated environment.
- c. **Determine Whether the Casualty is Nauseous.** Ask the casualty if he feels nauseous (feels as though he is going to vomit). If he does, encourage him to drink cool water (no salt added). Vomiting caused by drinking salty water will only result in the loss of more water and salt from the casualty's body. When the feeling of nausea has passed, give the casualty salty water to drink or salty food to eat.
- d. **Give Water and Salt.** If the casualty is not nauseous or the nausea has passed, give him water and salt to restore the body's natural fluid and salt balance. Dissolve 1/4 teaspoon of loose salt (same as one packet of salt from rations) in a canteen (one quart) filled with cool water. Have him drink the entire canteen over a one hour period. If no salt is available, have the casualty drink plain water. If he is still thirsty after drinking the salt solution, allow him to drink cool, unsalted water.
- e. **Observe Casualty.** Observe the casualty until the cramps disappear.
- f. **Evacuate, if Needed.** If the casualty continues to have severe cramps, evacuate him to a medical treatment facility. Enter pertinent information on the Field Medical Card and attach the form to the casualty's clothing.

## Section VI. HEAT EXHAUSTION

### 4-20. DEFINITION/CHARACTERISTICS

Heat exhaustion is a condition caused by excessive loss of water from the body (usually from sweating) without the water being adequately replaced. It usually occurs in otherwise fit individuals who are performing tasks requiring heavy physical work in a hot environment. Heat exhaustion is more serious than heat cramps, but the person will recover if the lost body fluid is replaced and if heatstroke does not develop.

#### 4-21. SIGNS/SYMPTOMS

a. **Most Common Signs and Symptoms.** A casualty with heat exhaustion will usually:

- (1) Perspire heavily.
- (2) Feel weak and dizzy.
- (3) Have skin that is pale and cool to the touch.
- (4) Have a headache.

b. **Other Signs and Symptoms.**

- (1) Loss of appetite.
- (2) Heat cramps.
- (3) Mental confusion.
- (4) Nausea (urge to vomit) with or without actual vomiting.
- (5) Urge to defecate.
- (6) Chills ("gooseflesh").
- (7) Rapid breathing (short of breath).
- (8) Tingling in the hands or feet.
- (9) Normal vital signs with an oral temperature that may be either slightly elevated or slightly below normal.

#### 4-22. TREATMENT

The basic cause of heat exhaustion is hypovolemia--an abnormal decrease in the volume of circulation fluid (plasma) in the blood system. The condition can be corrected by having the casualty drink water and by taking precautions to keep his condition from becoming worse.

a. **Protect Casualty from Sun.** Move the casualty to a shaded area or construct shade for the casualty.

b. **Loosen Clothing.** Loosen any tight-fitting clothing on the casualty if you are not in a chemically-contaminated environment.

c. **Cool Casualty.** If the day is very hot, pour water on the casualty and fan him. This will help the casualty's body to lose heat.

d. **Give Salt and Water.** Have the casualty drink at least one quart (one canteen) of the salt solution described in paragraph 4-19d. If salt is not readily available, have the casualty drink at least one quart of cool water.

e. **Elevate Legs.** Have the casualty lie down on his back and place a pack, small log, rolled up field jacket, or other stable prop under his feet. If a litter is available, have the casualty lie on the litter and elevate the foot of the litter. This procedure will help blood return from the casualty's legs to his heart and will help prevent shock.

f. **Evacuate, if Needed.** If the casualty is unable to drink water because of nausea or if the casualty's signs and symptoms do not improve after he begins drinking fluids, initiate intravenous infusion (Ringer's lactate or normal saline solution) and evacuate the casualty to a medical facility. (NOTE: Only trained personnel should attempt to initiate an IV.) Record information about the casualty's problem and his treatment on a Field Medical Card. Attach the form to the casualty's clothing.

## Section VII. HEATSTROKE

### 4-23. DEFINITION/CHARACTERISTICS

Whereas heat exhaustion may be regarded as the end result of a person's overactive heat-balance mechanisms that are still functioning, heatstroke results when the body's thermoregulatory mechanisms are not functional, and the main avenue of heat loss (cooling by evaporation of sweat) is blocked. Heatstroke should be regarded as a medical emergency which can lead to the person's death if the body temperature is not controlled adequately.

### 4-24. SIGNS/SYMPTOMS

a. Initially, there may be prodromal (indications of the onset of a disease or morbid state) symptoms of headache, malaise, and excessive warmth, or a general picture of heat exhaustion. Other signs and symptoms soon occur.

(1) The onset. The onset is usually abrupt with:

- (a) Sudden loss of consciousness.
- (b) Convulsions.
- (c) Delirium.

(2) Sweating. Sweating may or may not be absent in the typical case.



(3) Early stages:

(a) Temperature--elevated. Deep body temperature is frequently in excess of 106°F (41°C). Rectal temperature exceeding 108°F (42°C) is not uncommon and indicates poor prognosis.

(b) Skin--hot, flushed, perhaps dry.

(c) Severe cases--petechiae (pinpoint, nonraised, perfectly round, purplish-red spots caused by intradermal or submucous hemorrhage) may be present.

(d) Pulse--full and rapid.

(e) Blood pressure--systolic pressure may be normal or elevated. The diastolic pressure may be markedly depressed (60 mm Hg or lower).

(f) Respirations--rapid and deep, and simulate Kussmaul breathing (distressing, labored breathing occurring in spasms).

b. As the patient's condition worsens, these signs/symptoms occur:

(1) Cyanosis. A sign of cyanosis is a bluish discoloration especially of the skin and mucous membranes due to excessive concentration of reduced hemoglobin in the blood.

(2) Peripheral vascular collapse.

(3) Rapid pulse.

(4) Hypotension.

(5) Other symptoms. These symptoms may occur: pulmonary edema, incontinence, vomiting, hemorrhagic tendencies, disturbance of muscle tone, myocardial necrosis, meningismus, opisthotonos, jaundice, albuminuria, thrombocytopenia, and prolongation of the prothrombin time.

(6) Renal failure with rapidly developing hyperkalemia is not uncommon.

c. Death may ensue very rapidly but if the patient survives until the second day, the person usually recovers.

(1) For several days, rectal temperature of 102° to 103°F (39° to 40°C) may persist. During these days, mental disturbances, excitement, and delirium may continue or recur.

(2) Headache may persist for several weeks after the attack.

d. In the first few days after the temperature has been reduced from a critical level, severe relapses may occur.

(1) Observe the patient carefully during this period.

(2) Take and record the patient's rectal temperature frequently.

(3) At the first indication of a relapse, start treatment described in paragraph 4-19d.

#### **4-25. TREATMENT**

Heatstroke is treated by cooling the casualty's body. If the casualty is unconscious, be sure to check his breathing and heartbeat. Open his airway and administer rescue breathing or CPR if needed.

a. **Immediate Cooling.** Immerse the casualty in cool water or pour cool water onto the casualty and fan him.

b. **Evacuate.** Evacuate the casualty to the nearest medical treatment facility immediately.

c. **Other Cooling Procedures.** While waiting for transport or while evacuating the casualty, perform the following cooling procedures. Do not delay evacuation in order to begin these procedures.

(1) Remove the casualty's clothing and boots.

(2) Keep the casualty out of direct sunlight.

(3) Continue to pour water onto the casualty and fan.

(4) Have the casualty lie down and elevate his legs.

(5) Massage the casualty's arms and legs.

d. **Administer Fluids.**

(1) If the casualty is conscious, have him drink the salt solution described in paragraph 4-19d. If salt is not readily available, have the casualty drink at least one quart of cool water.

(2) If the casualty is unconscious, vomiting, or unable to retain fluids by mouth, start an IV of normal saline (NS) or Ringer's lactate. (NOTE: Only trained personnel should attempt to initiate an IV.)

e. **Initiate the Field Medical Card.** Initiate the Field Medical Card. Attach the card to the casualty's clothing.

#### **4-26. RISK FACTORS**

There are several factors which make a person more likely to suffer a heatstroke. Some of these factors are listed below.

a. **Previous Occurrence.** A person who has had a heatstroke is susceptible to another heatstroke if he is in a hot environment.

b. **Lack of Acclimatization.** A newly-arrived person whose body has not had a sufficient opportunity to adjust to warm weather is more likely to have a heatstroke than a person who has worked in the area for several weeks.

c. **Obesity.** A person is likely to have a heatstroke if he is overweight.

d. **Excessive Use of Alcohol.** Excessive use of alcohol can contribute to heatstroke.

e. **Age.** Older adults are more likely to have heatstroke than younger adults.

f. **General Health.** A person is more likely to have a heatstroke if he is suffering from dehydration, cardiovascular problems, lack of sleep, or poor general health.

### **Section VIII. PREVENTION OF HEAT INJURIES**

#### **4-27. INTRODUCTION**

a. In order for military personnel to perform their mission, there must be knowledge about how to prevent heat injuries. Successful prevention of heat injuries or disorders is the responsibility of both personnel who might be exposed to heat and those persons charged with the supervision of such personnel. The key to successful prevention of heat injuries includes the following: development of procedures to alert individuals to the existence of dangerous heat stress levels, the application of any practicable measures to reduce both the severity and the duration of the exposure, and the adoption of techniques to increase the resistance of exposed persons. Heat stress (exposure to high environmental temperature) produces stress on the body.

b. The severity of the effects of a given environmental heat load is decreased by reducing the work load, increasing the frequency and/or duration of rest or relief periods, and by introducing any measure which will protect a person from a hot environment. A person's resistance to heat can be increased by allowing the individual to gradually get used to the hot environment (become acclimatized), or by letting the person's work load be light at first and gradually increasing the work load each day. Resistance to a very hot climate can be increased also by making sure soldiers replenish water and salt they have lost. A final way to build up resistance to heat is to make sure soldiers working in heat are in the best physical condition possible.

#### **4-28. PREVENTIVE MEASURES**

##### **a. Water.**

(1) The human body is highly dependent on water to cool itself in a hot environment. An individual subjected to high heat stress may, by sweating, lose water in excess of one quart per hour. These losses must be replaced or rapid rise in body temperature and heart rate, decrease in the ability and motivation to work, and deterioration in morale will occur, followed eventually by heat exhaustion.

(2) Water loss must be replaced, preferably by periodic intake of small amounts of water throughout the work period. During moderate activity with moderate environmental conditions, the water requirement will be one pint or more per hour per person. This is best taken at 20 to 30 minutes intervals. As activities or conditions become more severe, the intake should be increased accordingly.

(3) Thirst is not an adequate stimulus for water intake. Individuals with ample water supplies will frequently dehydrate by one or two quarts unless drinking is encouraged or required by command control.

(4) The optimum drinking water temperature is between 50°F and 60°F (10°C and 16°C). It is a good idea to flavor the water lightly with citrus fruit flavors or extracts since this makes the water more tasteful.

(5) If water is in short supply, there are two ways to economize -- reduce physical activity or limit physical activity to early morning, evening, and night when the heat load is less and people sweat less. DO NOT attempt to conserve water by restricting water intake of personnel. The result is reduced work capability, reduced efficiency, and increased risk of a heat injury.

##### **b. Salt.**

(1) Sodium chloride as well as water is lost in sweating. A normal diet ordinarily contains an adequate amount of salt. An unacclimatized person will lose a greater amount of salt because of increased sweating than after acclimatization.

**NOTE:** Additional salt intake can delay the rate at which the full sweat product occurs. If salt is given in excess, a person can accumulate too much heat and have a higher body temperature than appropriate for the heat and current work load.

(2) Avoid excess intake of salt in the form of salt tablets because salt excess may increase thirst and cause intestinal disturbances.

**c. Acclimatization.**

(1) Training programs. Training programs for personnel who are climatically and/or physically unseasoned to heat should be limited in intensity and time. Allow a period of approximately two weeks with progressive degrees of heat exposure and physical exertion; this will allow for substantial acclimatization (about 78 percent). A period of acclimatization is necessary regardless of the individual's physical condition; although the better the physical condition, the quicker acclimatization is completed. If individuals are required to perform heavy physical work before being properly acclimatized, the work is done poorly, development of the capacity to work effectively is retarded, and the risk of heat injury and disability is high.

(2) Process of acclimatization. Acclimatization to heat begins with the first exposure and is usually developed to about 45 to 52 percent by the end of the first week. Individuals who are unusually susceptible to heat will require additional time for acclimatization. Full acclimatization (the ability to perform a maximum amount of strenuous work in the heat) is attained most quickly by graded, progressively increasing work in the heat. Full heat acclimatization can be achieved by as little as two 50-minute periods of work in the heat of each day. The work task should require cardiovascular endurance work (such as running in place) rather than muscle work (such as pushups).

(a) Resting for three or four days in the heat, with activity limited to that required for existence, results in only partial acclimatization. Physical work in the heat must be accomplished for development of full acclimatization to an acceptable work level in a given hot environment.

(b) A day or two of intervening cool weather will not interfere significantly with acclimatization to a hot climate.

(3) Work schedule during acclimatization period. If individuals must work during the acclimatization period, advantage should be taken of the cooler hours in accomplishing the work. A schedule should be established which provides for increasingly longer work periods alternating with rest periods.

(a) The plan which follows is suggested for troops other than basic trainees. It is not advisable for basic trainees to work in the heat during the basic training period when risk of heat injury is high. The schedule shown in table 4-1 should be modified to be consistent with local conditions.

	Moderate conditions WBGT or WD less than 80 <sup>0</sup> ; hours of work.		Severe conditions, WBGT or WD greater than 80 <sup>0</sup> ; hours of work.	
	Morning	After- noon	Morning	After- noon
First day	1	1	First day	1
Second day	1½	1½	Second day	1½
Third day	2	2	Third day	2
Fourth day	3	3	Fourth day	2½
Fifth day	Regular duty		Fifth day	3
			Sixth day	Regular duty

Table 4-1. Schedules of work during acclimatizing period.

(b) Divide the work period so that an individual works and rests in alternating periods. When it is necessary for the accomplishment of a given task, two details can be arranged to work in sequence.

(c) The schedule in table 4-1 is based on work equal to that of marching with a 20-pound pack at the rate of 2.5 miles per hour. Lighter work may be carried out for longer periods of time.

(d) Lighter work may be carried out for longer periods of time, while heavier work should be done for shorter time periods. During the midday period, individuals should rest and keep in the shade as much as possible. Peak wet bulb globe temperature (WBGT) conditions usually occur between 1200 and 1400 hours.

(e) Local and regional variations may warrant modifications of the work schedule in table 4-1. Also, acclimatization schedules for unseasoned individuals, including recruits, should be scaled down to their tolerance.

(4) Water. Provide adequate water for personnel during the acclimatization period as well as other times.

(5) Acclimatized personnel. Once acclimatized, personnel will retain most of their adaptation for about one week after leaving the hot environment. If these individuals are not exposed to work at high temperatures, their acclimatization will then decrease at a variable rate, the major part of acclimatization being lost within one month.

(6) Desert/jungle acclimatization. Acclimatization to a hot, dry (desert) environment increases markedly the ability of men to work in hot, moist (jungle) environments. However, for proper acclimatization to the jungle environment, living in the jungle with regulated physical activity is necessary. While carefully and fully developed acclimatization to a hot, dry environment increases resistance to heat, this acclimatization does not confer complete protection against the ill effects of heat, particularly moist heat.

(7) Meals. Under conditions of heat stress, meals should be cool rather than hot. The heaviest meal should be served in the evening rather than at noon. It is a good idea to have an hour of rest following the noon meal.

d. **Physical Condition.** How well an individual tolerates heat depends partly on the person's general physical condition. A person in very good physical condition will tolerate heat stress much better than an individual whose overall physical condition is poor.

e. **Work Schedule.** Tailor work schedules to fit the climate, the physical condition of personnel, and the military situation. Close supervision by medical officers, responsible commanders, and experienced paramedical personnel is essential in achieving maximum work output with minimum hazard. The following general principles must be considered.

(1) The amount of heat produced by the body increases directly with increasing work. Therefore, reduction of workload markedly decreases the total heat stress.

(2) Workloads and/or duration of physical exertion should be less during the first days of exposure to heat and should be gradually increased to allow acclimatization.

(3) Decisions to modify work schedules must be governed by the particular local situation, but generally heavy work should be scheduled for the cooler hours of the day--early morning or late evening.

(4) Alternate work and rest periods are desirable. Under moderately hot conditions, five-minute rest periods in the shade alternating with 25 minutes of work in the sun may be desirable. Under severe conditions, the duration of rest should be increased.

(5) Exposure to high temperature at night as well as in the daytime will decrease the amount of work individuals can perform effectively.

(6) Reduce work loads at high temperatures when personnel become dehydrated from excess sweating and there is a lack of water. If there is a shortage of water, schedule work in the early morning and evening. At these times, individuals can accomplish more work with less expenditure of water (sweating) than possible in the hotter hours of the day.

(7) Avoid having any individual work in the direct sun on hot days, as far as possible.

(8) Avoid personnel standing at attention in the heat unnecessarily. Continued standing places an added burden on the body's circulation.

(9) Curtail physical work when the temperature is excessively high. Under extreme conditions, suspend work. The temperature at which work should be curtailed or suspended depends on the humidity, radiant heat, air movement, character of the work, degree of acclimatization of personnel, and other factors. Heat casualties have been observed when the wet bulb globe temperature (WBGT) is 75°F (24°C) and lower. Overexertion can cause heat injury at even lower temperatures, especially if the person is wearing a heavy uniform or mission-oriented protective posture clothing (MOPP gear). MOPP gear is vapor impermeable clothing and allows no airflow to get through the clothing; consequently, the person wearing it can become very hot.

**f. Protection from the Environment.**

(1) Sunburn. Sunburn is caused by overexposure of the skin to the ultraviolet radiation of the sun. Severe cases are disabling and can predispose to other forms of heat illness. Sunburn can be prevented by using adequate shelter, clothing, sun screen lotions containing para-aminobenzoic acid or its derivatives, and limiting sequential exposure (exposure too long, several days in a row). Fair-skinned individuals should be particularly careful, although dark-skinned individuals can also be sunburned.

(2) Clothing. A person is better off in a hot environment wearing the least allowable amount of clothing (except when exposed directly to the sun's rays). Clothing reduces the exposure of the body surface to solar radiation. At the same time, clothing decreases the movement of air over the skin. So, to take full advantage of the benefits and minimize the disadvantages, clothing should be loose fitting to allow circulation of air, especially at the neck, wrists, and lower legs.

NOTE: Protection from the environment also includes such simple but frequently overlooked things such as marching troops over grass rather than concrete and operating in such shade as is available.



#### **g. Special Considerations in Recruit Training.**

(1) Basic trainees make up a special group of unseasoned personnel who need particular attention because of the unusual physical stresses involved in basic training in summer heat. Adjustment to this stress is difficult and must be taken into account in planning training schedules. It is best to plan work and schedule training activities for the coolest parts of the day. This will yield greater efficiency and less disruption of training than will insistence on routine completion of a heavy schedule.

(2) Heat casualties occur most frequently during the first two weeks of basic training and during the bivouac week. These casualties are associated especially with firing on the rifle range, squad tactical training, and retreat parades. Particular attention should be paid to decreasing the heat strain accompanying these activities.

(3) Recruit heat casualties tend to occur in groups within particular units. Responsible commanders and medical officers should, therefore, promptly investigate each case to determine the unsafe practice or condition responsible. Measures should be instituted to prevent additional cases.

#### **h. Special Consideration in Troop Transportation to Tropical Combat Zones.**

(1) Transportation by ship. Troops being transported by ship to tropical combat zones need two 50-minute periods of vigorous exercise daily to maintain physical fitness and to begin acclimatization to heat. The type of exercise should stress the cardiovascular system rather than development of muscle power. For example, running in place is a better exercise in this situation than lifting (pushups).

(2) Transportation by air. Troops transported by air to tropical combat zones may be injected into combat situations in hot environments without being able to become acclimatized. In this case, all possible steps to induce heat acclimatization prior to deployment should be attempted.

**i. Special Consideration in Armed Forces Industrial-Type Settings Ashore.** In addition to preventing the adverse effects of heat in military situations and physical activity in military training, there are WBGT threshold values for instituting proper preventive measuring during hot weather in Armed Forces industrial-type settings ashore. When WBGT values are reached for the hottest two-hour period of the industrial work shift, the health practices described in paragraph 4-28 of this section become particularly necessary.

**NOTE:** Do not confuse the WBGT threshold values with the PHEL (physiological heat exposure limits). The PHEL deals with maximum time-weighted-mean limitations on an individual's work capacity in hot environments.

**j. Special Consideration in Hot Environments Afloat.**

(1) In certain environments afloat, heat frequently exceeds man's ability to adapt. Therefore, exposure limits for high heat stress areas afloat have been established through use of the PHEL (physiological heat exposure limits), described in detail in Navy Medical Department publication NAVMED P-5010-3, Manual of Naval Preventive Medicine.

(2) The PHEL's are maximum allowable conditions of work. The PHEL concept should be applied only in cases of short-term work exposures of up to eight hours duration. The limits presume that no prior heat injury is present and that no cumulative fatigue exists prior to reexposure.

(3) The physiologic impact of repetitive exposures to heat stress over the span of several days is the subject of scientific investigations. The PHEL concept is based upon a comprehensive set of physiologic criteria of heat tolerance that is reversible without evidence of presistent injury.

**k. Education.**

(1) Prevention of heat injuries depends largely on educating two groups of people: personnel who will be exposed to extreme heat and those who supervise these personnel. Everyone who will be exposed to unaccustomed high temperatures, personnel and their supervisors or commanders, should be aware of the following.

- (a) The potentially serious results of heat injury.
- (b) The general nature of heat injuries.
- (c) How heat injuries can be prevented.

(2) Supervisors and responsible officers must be able to identify environmental conditions which make heat injuries likely to happen. They should be able to recognize the earliest signs of heat injury and take appropriate action to prevent the heat injury from happening. For example, mental confusion and overactivity commonly precede collapse from heatstroke. Supervisors must be alert to detect these conditions, then to enforce rest, and to obtain medical assistance promptly.

(3) Responsible medical officers should assist commanders in the development of local programs for heat injury prevention and continuously observe and advise in its application.

(4) All personnel should be trained so that each person is capable of administering effective first aid for heat injury.

#### 4-29. WET BULB GLOBE TEMPERATURE (WBGT) INDEX

a. **Equipment.** The WBGT index is computed from readings of the following: a stationary wet bulb thermometer exposed to the sun and to the prevailing wind, a six inch black globe thermometer similarly exposed, and a dry bulb thermometer shielded from the direct rays of the sun. All readings are taken at a location representative of the conditions to which people are exposed. The web bulb and globe thermometers are suspended in the sun at a height of four feet above ground. A period of at least 20 minutes should elapse before readings are taken.

(1) The wet bulb thermometer. This thermometer is a standard laboratory glass thermometer with its bulb covered with a wick (heavy white shoe-string). The wick dips into a flask of clean, preferably distilled, water. The mouth of the flask should be about three-fourths of an inch below the tip of the thermometer bulb. The water should be changed daily after rinsing out the flask and washing the wick with soap and water. To avoid incorrect readings, the water and wick must be free of salt and soap.

(2) The globe thermometer. The usual globe thermometer apparatus consists of a six inch hollow copper sphere painted flat black on the outside and containing a thermometer with its bulb at the center of the sphere. The thermometer stem protrudes to the outside through a stopper tightly fitting into a brass tube soldered to the sphere. The sphere has two small holes near the top used for suspending the sphere with wire or strong cords. The globe must be kept a dull black at all times, free of dust or rain streaks, by dusting, washing, or repainting if necessary.

#### b. **The Method of Computing the WBGT Index.**

$$\begin{aligned} \text{WBGT} = & 0.7 \times \text{wet bulb temperature.} \\ & + 0.2 \times \text{black globe temperature.} \\ & + 0.1 \times \text{shaded dry bulb temperature.} \end{aligned}$$

#### c. **Use of the WBGT Index in Control of Physical Activity.**

(1) Measurements must be taken in the same location or a location similar to the environment in which soldiers will be working, exercising, etc.

(2) Look at table 4-2 for recommendations for physical activity for various temperatures on the WBGT Index.

<b><u>WBGT Index</u></b>	<b><u>Recommendations</u></b>
78°F (26°C)	Use caution. Extremely intense physical exertion may bring on heat exhaustion or heatstroke.
82°F (28°C)	Use discretion in planning heavy exercise for unseasoned personnel.
85°F (29°C)	Suspend strenuous exercise such as marching at standard cadence for unseasoned personnel during their first three weeks of training. Training activities may be continued on a reduced scale after the second week of training.
above 85°F (29°C)	Avoid outside classes in the sun when the WBGT is over this WBGT Index.
88°F (31°C)	Stop strenuous exercise for all recruits and other trainees with less than 12 weeks training in hot weather. Hardened personnel, after having been acclimatized each season, can carry on limited activity at WBGT Index of 88°F to 90°F (31°C - 32°C) for periods not exceeding six hours a day.
90°F (32°C)	Suspend physical training and strenuous exercise and above <u>for</u> all personnel (excluding essential operational commitments not for training purposes, where the risk of heat casualties may be warranted).
<b>NOTE:</b> Wearing of <u>body armor</u> or <u>NBC warfare protective uniforms</u> in effect adds 10°F (6°C) to the measured WBGT. Activity limits should be adjusted accordingly.	

Table 4-2. Physical activity recommendations.

**Continue with Exercises**

## EXERCISES, LESSON 4

**INSTRUCTIONS.** The following exercises are to be answered by marking the response that best answers the question or best completes the incomplete statement or by writing the answer in the space provided.

After you have completed all the exercises, turn to the solutions at the end of the lesson and check your answers. For each exercise answered incorrectly, reread the material referenced after the solution.

1. List the three types of heat injury.
  - a. \_\_\_\_\_.
  - b. \_\_\_\_\_.
  - c. \_\_\_\_\_.
  
2. Human beings are homeothermic which means that humans are capable of \_\_\_\_\_.
  
3. A human's body temperature is maintained in two ways: by heat \_\_\_\_\_ and heat \_\_\_\_\_.
  
4. The \_\_\_\_\_ rate is the term for the rate at which the body produces heat.
  
5. The body produces heat by \_\_\_\_\_ activity, \_\_\_\_\_ or metabolic rate, \_\_\_\_\_ intake, external temperature, and certain \_\_\_\_\_.
  
6. Two other ways the body produces heat are tissue contractions and \_\_\_\_\_, the latter containing a large volume of water which absorbs heat and acts as a coolant.

7. List four heat loss outlets.

- a. \_\_\_\_\_.
- b. \_\_\_\_\_.
- c. \_\_\_\_\_.
- d. \_\_\_\_\_.

8. List two means to keep from losing too much heat, one artificial way and one natural way.

- a. Artificial = \_\_\_\_\_.
- b. Natural = \_\_\_\_\_.

9. List five heat transfer mechanisms discussed in this lesson.

- a. \_\_\_\_\_.
- b. \_\_\_\_\_.
- c. \_\_\_\_\_.
- d. \_\_\_\_\_.
- e. \_\_\_\_\_.

10. If the body loses heat in heat waves from the body to cooler objects, the heat transfer mechanism is \_\_\_\_\_.

11. List three conditions which make a difference in a person's ability to withstand heat.

- a. \_\_\_\_\_.
- b. \_\_\_\_\_.
- c. \_\_\_\_\_.

12. Heat cramps are \_\_\_\_\_  
\_\_\_\_\_.
13. A person who has been working in hot weather and losing too much salt is liable to suffer from \_\_\_\_\_.
14. To treat a person for heat cramps, you should protect the casualty from the \_\_\_\_\_, \_\_\_\_\_ his clothing, determine whether the casualty is nauseous, and, if the casualty is not, give the casualty \_\_\_\_\_.
15. Heat exhaustion is \_\_\_\_\_  
\_\_\_\_\_.
16. List three signs/symptoms of heat exhaustion.
- a. \_\_\_\_\_.
  - b. \_\_\_\_\_.
  - c. \_\_\_\_\_.
17. Measures you should take in treating a casualty of heat exhaustion include protecting the casualty from the \_\_\_\_\_, loosening his \_\_\_\_\_, cooling the casualty, giving the casualty \_\_\_\_\_ and \_\_\_\_\_ (if not nauseous), elevating the casualty's \_\_\_\_\_, and \_\_\_\_\_, if needed.
18. Heatstroke occurs when the body's thermoregulatory mechanisms \_\_\_\_\_  
\_\_\_\_\_.

19. Early symptoms of heatstroke include sweating, convulsions, and sudden loss of \_\_\_\_\_
20. Heatstroke should be regarded as a medical emergency which can lead to \_\_\_\_\_ if the body temperature is not adequately controlled.
21. Cooling procedures you use when treating a casualty of heatstroke include removing the casualty's \_\_\_\_\_, keeping him out of direct \_\_\_\_\_, pouring \_\_\_\_\_ onto the casualty and fanning him, having the casualty lie down and elevating his \_\_\_\_\_, and massaging the casualty's \_\_\_\_\_ and \_\_\_\_\_.
22. List three factors which could make a person more likely to suffer heatstroke.
- a. \_\_\_\_\_.
  - b. \_\_\_\_\_.
  - c. \_\_\_\_\_.
23. List four measures which can be taken to prevent heatstroke.
- a. \_\_\_\_\_.
  - b. \_\_\_\_\_.
  - c. \_\_\_\_\_.
  - d. \_\_\_\_\_.

**Check Your Answers on Next Page**



## SOLUTIONS TO EXERCISES, LESSON 4

1. Heat cramps.  
Heat exhaustion.  
Heatstroke. (para 4-3b)
2. Maintaining a nearly constant body temperature. (para 4-4)
3. Production.  
Dissipation. (para 4-4)
4. Metabolic. (para 4-5a)
5. Muscular. (para 4-5a(1))  
Glandular. (para 4-5a(2))  
Food. (para 4-5a(3))  
Hormones. (para 4-5a(5))
6. Blood flow. (para 4-5c)
7. Respiratory system.  
Skin.  
Urine.  
Feces. (paras 4-6a, b)
8. Artificial = wear appropriate clothing.  
Natural = subcutaneous fat. (para 4-7)
9. You are correct if you listed these in any order.  
Evaporation. (para 4-10)  
Radiation. (para 4-11)  
Conduction. (para 4-12)  
Convection. (para 4-13)  
Cardiovascular role. (para 4-14)
10. Radiation. (para 4-11)

11. You are correct if you listed any three of the conditions listed below.
  - Infections.
  - Febrile Conditions.
  - Immunizations (Reactions).
  - Vascular Diseases.
  - Diarrhea.
  - Conditions Affecting Sweat Secretion.
  - Skin Trauma.
  - Previous Heat Injury. predisposed to future attacks of heat injury.
  - Recent Use of Alcohol/Drugs.
  - Chronic Use of Diuretics.
  - Dehydration.
  - Lack of Sleep.
  - Age--persons over 40 years old.
  - Poor personal hygiene.
  - Poor general health.
  - (paras 4-15a through 4-15m)
12. Painful cramps of the voluntary muscles, usually of the arms, legs, or abdomen.  
(para 4-17)
13. Heat cramps. (para 4-17)
14. Sun. (para 4-19a)  
Loosen. (para 4-19b)  
Water and salt. (para 4-19d)
15. A condition caused by excessive loss of water from the body without the water being adequately replaced. (para 4-20)
16. You are correct if you listed any three of the following
  - Perspire heavily.
  - Feel weak and dizzy.
  - Have skin that is pale and cool to the touch.
  - Have a headache.
  - Loss of appetite.
  - Heat cramps.
  - Mental confusion.
  - Nausea (urge to vomit) with or without actual vomiting.
  - Urge to defecate.
  - Chills ("gooseflesh").
  - Rapid breathing (short of breath).
  - Tingling in the hands or feet.
  - Normal vital signs with an oral temperature that may be either slightly elevated or slightly below normal.
  - (paras 4-21a, 4-21b)

17. Sun. (para 4-22a)  
Clothing. (para 4-22b)  
Water and salt. (para 4-22d)  
Legs. (para 4-22e)  
Evacuating the casualty. (para 4-22f)
18. Are not functioning. (para 4-23)
19. Consciousness. (para 4-24a(1))
20. The person's death. (para 4-23)
21. Clothing and boots. (para 4-25c(1))  
Sunlight. (para 4-25c(2))  
Water. (para 4-25c(3))  
Legs. (para 4-25c(4))  
Arms and legs. (para 25c(5))
22. You are correct if you listed any three of the following:  
Person had heatstroke previously. (para 4-26a)  
Person is not used to hot weather. (para 4-26b)  
Person is very overweight. (para 4-26c)  
Person drinks too much alcohol. (para 4-26d)  
Person is an older adult. (para 4-26e)  
Person is in poor general health. (para 4-26f)
23. You are correct if you listed any four of the following:  
Be sure personnel drink an adequate amount of water. (para 4-28a)  
Be sure personnel get the proper amount of salt. (para 4-28b)  
Carefully acclimatize those who are new to hot weather. (para 4-28c)  
Stress good physical condition to all personnel. (para 4-28d)  
Tailor the work schedule to fit the climate. (para 4-28e)  
Prevent sunburn by means of sunscreen, exposure, etc. (para 4-28f(1))  
Be sure personnel wear appropriate clothing for a hot climate. (para 4-28f(2))

## **End of Lesson 4**

## LESSON ASSIGNMENT

### LESSON 5

Cold Injuries.

### LESSON ASSIGNMENT

Paragraphs 5-1 through 5-16.

### LESSON OBJECTIVES

After completing this lesson, you should be able to:

- 5-1. Identify the four degrees of cold injury, command responsibilities, and factors which impact on cold injuries.
- 5-2. Identify the causes, symptoms, and treatment for chilblains.
- 5-3. Identify the causes, symptoms, and treatment for immersion/trench foot.
- 5-4. Describe frostbite and identify the signs/symptoms and treatment for frostbite.
- 5-5. Identify the symptoms, physiologic reaction, and treatment for hypothermia.

### SUGGESTION

After studying the assignment, complete the exercises of this lesson. These exercises will help you to achieve the lesson objectives.

## LESSON 5

### COLD INJURIES

#### Section I. CHARACTERISTICS/GENERAL FINDINGS OF COLD INJURIES

##### 5-1. INTRODUCTION

Cold injury occurs sporadically among the civilian population, but our primary concern is cold injury and its affect on the military forces. Since the days of Xenophon and Alexander of Macedonia, cold injury has been recorded as a problem of military importance. Larrey classically described the role that cold injury played in the defeat of Napoleon's Army in Poland in 1812. The United States had considerable experience with cold injury during World War II. In the U.S. Army, there was a total incidence of 90,535 time-lost injuries which included trench foot and frostbite in ground troops and high altitude frostbite in air crews. In Korea, United States troops experienced more than 9,000 cases of cold injury, chiefly frostbite in ground troops. Over 8,000 of these cases occurred in the winter of 1950-1951.

a. Cold injury is defined as tissue trauma produced by exposure to cold. The type of injury produced depends upon the degree of cold to which the body (or its parts) is exposed, the duration of exposure, and certain concurrent environmental factors. For practical purposes, cold injuries may be divided simply into "freezing" and "nonfreezing" types. The former is the well-known frostbite (superficial or deep). The nonfreezing types are chilblain, trench foot, and immersion foot.

b. There exists no real justification for distinguishing between trench foot and immersion foot with respect either to pathology or management, nor even to environmental conditions which are causative. Both result from prolonged exposure of the feet to wet cold: trench foot to cold, wet socks and boots; immersion foot to cold water--with or without socks and boots.

c. Chilblains is the only cold injury which is not of significant military importance.

d. Definitions of nonfreezing cold injuries.

(1) Chilblains. Chilblains result from intermittent exposure to temperatures above freezing accompanied by high humidity.

(2) Trench foot/immersion foot. These result from prolonged exposure to wet, cold foot gear or outright immersion of the feet at temperatures usually below 50°F. At the upper range of temperatures, exposure of 12 hours or more will cause injury. Shorter durations at or near 32°F will cause the same injury.

e. Definition of a freezing cold injury. Frostbite results from crystallization of tissue water in the skin and adjacent tissues and is produced by exposure to temperatures below the freezing point. The depth and severity of the injury is a function of the temperature and the duration of exposure--the lower the temperature, the shorter the time required to produce injury. At low temperatures in the presence of wind, freezing of exposed skin can occur within a few seconds.

## 5-2. EPIDEMIOLOGY

Cold injury in a military population behaves in general according to accepted epidemiologic principles. A specific agent is present and a variety of environmental and host factors influence the incidence, prevalence, type, and severity of the injury. These factors combine in the total causation of cold injury, and the influence of each may vary in every situation. Careful evaluation of these factors and their relative effects serves to guide prevention and control activities and dictates specific measures which must be employed according to condition in the unit concerned.

a. **Agent Factor.** Cold is the specific agent in cold injury and is the immediate cause of tissue damage. However, if cold is causing loss of body heat which is, in turn, causing injury to the body, then factors such as radiation, conduction, convection, and evaporation must be considered. In other words, the effect of cold cannot be evaluated only by the temperature of the air.

(1) Radiation -- Transfer of heat from the body to an object without physical contact.

(2) Conduction -- Transfer of heat from the body to an object in physical contact such as clothing.

(3) Convection -- Cool air making contact with the body and carrying away body warmth.

(4) Evaporation -- Perspiration.

### b. **Environmental Factors.**

(1) Weather. Weather is a major influence in causing cold injury. The rate of body heat loss is affected by temperature, humidity, precipitation, and wind. Low temperatures and low relative humidity favor frostbite, whereas higher temperatures together with moisture are usually associated with trench foot. Wind velocity accelerates body heat loss under both wet and cold conditions. The windchill effect is shown in table 5-1 and should be thoroughly understood by all personnel in areas where cold injury is possible. The equivalent temperature shown on the windchill chart relates to the cooling effect on exposed skin, primarily face or ears. When considering host factors in general, personnel should recognize that increasing wind is a significant factor in body heat loss.

(2) Type of combat action. The incidence of cold injury varies according to type of combat action. Units in reserve or in rest areas have few cases. In holding missions or on static defense, exposure is greater and a moderate increase in incidence is expected. On active defense or offense, marked increases usually occur. Immobility under fire, prolonged exposure, lack of opportunity to rewarm and change clothing or carry out personal hygienic measures, fatigue, and state of nutrition may all be involved.

(3) Clothing. In warfare, where exposure to cold may be prolonged, adequate clothing properly worn is essential to welfare and survival. Clothing for cold weather combat has been designed to be worn as an assembly for protection of the head, torso, and extremities. Failure to wear the total assembly and inadequate supplies of proper sizes of clothing are important factors in cold injury.

(a) Cold weather clothing depends on the layering principle to conserve body heat. Loose layers of clothing with air space between them, under an outer wind-resistant and water-resistant garment provide maximum protection. Layers of clothing may be removed for comfort and efficiency to permit perspiration to escape when the temperature is higher or during strenuous physical exertion.

(b) Clothing which is wet from perspiration loses much of its insulating value. Care must be taken to prevent perspiration from accumulating in the clothing.

(c) In all forms of cold injury, prevention of loss of body heat is important. All articles of clothing must be loose to avoid constriction and tightness. Clothing must be kept free of grease and dirt.

**c. Host Factors.**

(1) Age. Within the usual age range of combat personnel, age is not significant.

(2) Rank. Trench foot and frostbite occur primarily in front line riflemen, predominantly those of lower ranks. The decreased incidence of cold injury among higher ranks is the reflection of a combination of factors such as possible lesser degree of exposure, experience, and receptivity to training.

(3) Previous cold injury. A person who has had a cold injury (frostbite or trench foot) has a greater possibility of another cold injury, not necessarily involving the part of the body previously injured. An individual who has had a minor degree of superficial cold injury which has completely healed is not more susceptible to future cold injury. This individual does not require profiling or assignment restrictions.

(4) Fatigue. Fatigue is a contributing factor to cold injury. Mental tiredness can cause individuals to neglect acts vital to survival. This occurs more frequently in personnel who have been in combat for 30 days or more without rest. Frequent rotation of troops from the front lines for even short periods lessens the influence of the fatigue factor.

(5) Concomitant injury. Experience has shown that injuries resulting in significant blood loss or shock reduce effective flow of blood to the extremities. This causes the individual to be predisposed to cold injury.

(6) Discipline, training, and experience. COLD INJURES ARE PREVENTABLE. Proper use of simple preventive measures which are inspected and enforced by officers and noncommissioned officers will markedly reduce the incidence of cold injury. Individual and unit discipline, training, and experience are closely related in their influence upon the incidence of cold injury. Well-trained and disciplined personnel suffer less than others from the cold because they are better able to care for themselves through personal hygiene, care of feet, change of clothing, exercise of the extremities in pinned-down positions, and similar effective measures.

(7) Psychosocial factors. Cold injury tends to occur in passive, negativistic individuals, who tend to display little muscular activity and are prone to pay less attention to carrying extra footwear and changing of socks when needed.

(8) Race. In terms of numbers at risk, and independent of geographic origin, African-Americans appear to be considerably more vulnerable to frostbite than Caucasians. This has been a consistent observation dating from World War II through Korea and into the present in Alaska. It suggests that African-Americans must be particularly vigilant respecting hand and foot care during cold exposure. By training and proper use of protective clothing, the African-American soldier can overcome this physiological handicap and serve in cold climates without excessive risk of cold injury.

(9) Geographic origin. Caucasian personnel from warmer climates in the United States (where the mean minimum January temperature is above 20°F) appear to be predisposed to cold injury. The basic factor involved, however, may be caused by psychological, social, and education factors rather than geographic factors.

(10) Nutrition. Starvation or semi-starvation predisposes to cold injury. Adequately clothed and protected personnel in cold climates do not require more than the normally provided military ration of 3600 to 4600 calories per day. Evidence of a need for specific nutrients in the diet for cold injury or treatment is lacking. However, the increased exercise requirements imposed by heavy clothing and equipment and the increased difficulty of movement in snow-covered terrain can increase caloric requirements up to 7000 per day. For example, cross-country skiing can require the expenditure of between 600 to 1200 calories per hour.



(11) Activity. Too great or too little activity may contribute to cold injury. Overactivity can cause the loss of large amounts of body heat by perspiration. The perspiration becomes trapped in excess clothing thus reducing the insulating quality of the clothing. On the other hand, immobility causes decreased heat production and the danger of cooling, especially in the extremities and pressure areas of the body.

(12) Drugs and medication. Doctors should advise patients of any adverse effects on circulation or sweating when prescribing drugs and medication in cold climates. Morphine is an important example of a drug with a significant effect on cutaneous (skin) circulation and, therefore, on body heat balance. Chlorpromazine, barbiturates, and clopenthixol are other drugs which can predispose to cold injury.

(13) Alcohol. Because of its questionable vascular effects coupled with its influence on judgment, alcohol should be avoided under conditions of extreme cold. The dangers of hypothermia and frostbite are increased greatly under its influence.

### **5-3. DEGREES OF COLD INJURY**

Early evaluation of the severity of injury is extremely difficult even to the most experienced medical officer. Definitive classification of severity of cold injury into first, second, third, and fourth degree is possible only in retrospect, after the case is completed. However, since at the two extremes, there can be some clinical distinction, this classification has some value.

#### **a. First Degree--Hyperemia and Edema.**

- (1) After rewarming, skin becomes mottled, cyanotic, red, hot, and dry.
- (2) Apparent hyperemia (excess of blood in a part), blanches (becomes lighter) poorly when pressed, and capillary filling is sluggish or absent.
- (3) There frequently is intense itching or burning; later, there is a deep seated ache.
- (4) Swelling begins within three hours and may persist for ten more days if the individual remains on duty.
- (5) Edema usually disappears in less than five days if the patient is kept at bed rest.
- (6) Shedding of the superficial layers of skin may begin within five to ten days after injury and may continue as long as a month.

(7) In very severe cases, deep aching pain, paresthesia (burning, prickling, a morbid sensation), cyanosis (blueness of the skin from imperfectly oxygenated blood), hyperhidrosis (excessive perspiration), and coldness of the injured part may appear two or three weeks after the injury has occurred and persist for many months. In milder cases, symptoms may persist for several hours, causing intense discomfort but gradually disappearing without serious consequences.

**b. Second Degree--Hyperemia and Vesicle Formation.**

(1) Hyperemia, edema, and burning pain occur soon after rewarming.

(2) The skin becomes deep red, with mottled cyanosis and feels hot and dry to the touch.

(3) Swelling begins within two or three hours.

(4) There may be a sensation of tingling and burning which gradually becomes more intense; light touch and position sense are frequently absent.

(5) In severe cases, blisters and huge blebs (large, soft sacs) may appear within six to twelve hours. The large, clear appearance of these blebs appearing early and extending nearly to the tips of involved fingers or toes is generally felt to be a valuable sign identifying the injury as second degree.

(6) Pain, usually a deep, aching sensation in association with intense burning, increases and may require medication.

(7) Edema is usually not marked and disappears within three to five days after rewarming if the patient is not ambulatory.

(8) The vesicles (small sacs or cysts) appear in the germinative layer of skin and frequently occur on the great toe and heel or the back of one or more fingers. These vesicles dry, forming black scabs within 10 to 24 days after rewarming.

(9) There may be slight limitation of motion in the injured part of the body, fingers or toes for example.

(10) Throbbing or aching pain is usually noted 10 to 20 days after injury.

(11) Hyperhidrosis (excessive perspiration) frequently occurs between the second and the third week.

(12) The scab gradually separates, revealing intact skin which is thin, soft, poorly keratinized, and easily injured.

**NOTE:** Keratin is a protein found in the outermost layer of the skin. Keratin is waterproof, resistant to friction, and helps resist bacterial invasion.

c. **Third Degree--Necrosis of Skin and Cutaneous Tissue.** This injury involves whole skin thickness and extends into subcutaneous tissue leading to ulceration.

(1) Vesicles may be present but are more commonly bluish-purple in color and hemorrhagic, smaller, and do not extend to the tip of the involved fingers or toes.

(2) Edema of the entire foot or hand is usually present and appears in an average of six days.

(3) Most patients have burning, aching, throbbing, or shooting pains beginning on the 5th to 17th day following an early period of anesthesia.

(4) The skin overlaying the area of third degree frostbite may form a black, hard, dry scab.

(5) The scab finally separates, exposing underlying granulation tissue (newly formed tissue produced in the healing of wounds).

(6) Healing occurs in an average of 68 days.

(7) Hyperhidrosis (excessive perspiration) and cyanosis may appear between the fourth to tenth week after the injury and persist for months. This results in a prolonged, uncomfortable convalescence.

(8) Trauma and infection due to injury other than cold may complicate the degree of injury and result in extensive tissue loss, systemic manifestations of infection, and even wet gangrene requiring emergency amputation.

d. **Fourth Degree-Complete Necrosis and Loss of Tissue.** There is a destruction of the entire thickness of the part including bone resulting in loss of the injured part.

(1) Upon rewarming, the skin may turn deep red, purple, or appear mottled and cyanotic.

(2) The area involved is usually anesthetic (not sensitive to pain/physically insensitive).

(3) Although there may be rapidly developing edema (abnormal accumulation of fluid in body tissues) proximal (nearer the attachment of the extremity to the body trunk) to the area of fourth degree injury, reaching a maximum within 6 to 12 hours, the injured area itself may show no significant increase in volume, but rapidly progress to dry gangrene and mummification.

(4) In other fourth degree injuries, tissue injury slowly progresses, edema is more prominent. Scab formation and gangrene may not be evident until two or three weeks after the injury.

(5) Severe paresthesia (abnormal sensation of prickling, itching, and such) may appear 3 to 13 days after rewarming.

(6) The line of cold injury becomes apparent in an average of 36 days and extends down to the bone between 60 to 80 days after injury.

#### **5-4. PREVENTION**

a. **Cold Injuries are Preventable.** Successful prevention requires vigorous command leadership and proper use of preventive measures which are inspected and enforced. Prior planning, cold weather training, and the provision of proper clothing and equipment are of primary importance. Specific preventive measures are directed toward conservation of total body heat, avoiding unnecessary prolonged exposure of personnel to cold, moisture, and activities favoring cold injury.

b. **Meteorological Data.** All commanders should be familiar with the utilization of simple meteorological data such as humidity, temperature, wind, and ground surface conditions which influence the risk of cold injury. Some weather conditions will require shortening of the exposure time of individuals engaged in patrols, guard, or motor movements in unheated vehicles despite the adequacy of their clothing and equipment. These can frequently be anticipated by the utilization of meteorological data and existing weather conditions to predict the hazard for the ensuing 12-hour period. Thus, clothing may be provided for anticipated weather conditions and the periods of exposure shortened, if indicated.

c. **Cold Injury Control Officer.** Each platoon and squad or comparable-sized unit should have a Cold Injury Control Officer or Noncommissioned Officer. This individual should be carefully selected on the basis of leadership, interest, and ability to supervise others in simple but constant preventive activities. This officer's responsibilities include the following.

(1) Observing soldiers frequently for early signs and symptoms of cold injury.

(2) Daily check of soldiers for good personal hygiene, especially when a change of socks at appropriate intervals, along with a reasonable effort to keep the feet clean and dry is essential.

(3) Encouraging efforts of soldiers to take appropriate exercises and to avoid constriction of the extremities by clothing and footgear.

**d. The Buddy System.** Members of squads and patrols should be taught to observe their companions for evidence of cold injury. If a part of a soldier's skin suddenly blanches and someone notices the blanching promptly, immediate care will usually prevent the development of a more serious cold injury. Holding (not rubbing) a warm hand on the blanched area of an ear, nose, or cheek until a normal color has been restored will be adequate rewarming. The part must then be protected against further serious exposure to cold. Fingers can be warmed against the skin of the abdomen or the armpit. Toes can be warmed by holding them against a companion's chest or abdomen under that person's outer clothing. A fairly reliable symptom of incipient frostbite of fingers and toes is the sudden and complete cessation of the sensation of cold or discomfort in that part. This is often followed by a pleasant feeling of warmth. If these danger signals are instantly heeded, cold injury can be prevented.

**e. Clothing.**

(1) A standard number of layers of clothing cannot be prescribed for universal wear throughout winter months. Flexibility must be provided for local conditions. Certain basic principles are important, including the ventilation of the body during physical activity, the cleanliness and repair of clothing to prevent loss of insulation, and the avoidance of constriction produced by snug fitting socks, boots, underwear, sweaters, jackets, and trousers.

(2) In all types of footgear, feet perspire more and are generally less well ventilated than other parts of the body. Since moisture accumulates in socks, decreasing their insulating quality, all ground personnel should carry an extra pair of socks.

**f. Directives in Use of Clothing.**

(1) When working, remove excess layers of clothing before perspiration starts so that clothing does not become wet. Avoid wetting clothing or footgear, since moisture causes loss of insulating quality.

(2) Wear clothing and footgear loose enough to permit layers of air to provide good insulation and to permit good circulation of blood to all parts of the body. Avoid tight-fitting uniforms; they are dangerous in cold climates.

(3) Keep hands well protected; mittens are more protective than gloves. Avoid lengthy exposure of bare hands and wrists that will cause stiffening and reduce circulation, since it takes a long time to recondition the hands to normal use.

**CAUTIONS:** DO NOT TOUCH METAL, SNOW, OR OTHER COLD OBJECTS WITH BARE HANDS. DO NOT SPILL GASOLINE ON SKIN OR CLOTHING.

(4) To generate and maintain body heat, have soldiers perform activities which involve the body's large muscle groups of the shoulders, trunk and legs. If such activity is not possible, soldiers can change body position, move toes, feet, legs, fingers, arms, and hands. Isometric contractions can be done. Also, some delay in heat loss can be accomplished by sitting or standing on insulating material such as wood, cardboard, or other poor conductors rather than on cold or wet ground or snow.

(5) Remove excess clothing when in a warm enclosure or in front of a fire to avoid sweating and undue dilation of skin blood vessels.

## **Section II. NONFREEZING COLD INJURIES**

### **5-5. CHILBLAINS**

a. **Definition/Characteristics.** Chilblains are an inflammation of the hands and feet caused by exposure to cold and moisture. This is the only cold injury which is not of military importance.

b. **Causes.** Chilblains result from intermittent exposure to cold temperatures above freezing, accompanied by high humidity.

c. **Signs/Symptoms.** Chilblains are characterized by skin (usually on the hands, feet, or ears) that is red, swollen, itching, tingling, tender, and hot to the touch. Later there may be a deep-seated ache. The affected body part; for example, a finger, may swell to 15 percent more than its normal size. Continued exposure results in sores (lesions) on the surface of the skin. These sores may bleed and become ulcerative (inflamed open sores) in which the skin dies and is sloughed off.

d. **Physiological Action.** During exposure to the cold, the small blood vessels in the skin of the extremities and then in the large arteries constrict. Later, the smallest blood vessels dilate.

e. **Treatment.** Warm the patient and the affected part. Acute inflammatory reaction in the extremities subsides within a few hours after exposure.

## 5-6. IMMERSION/TRENCH FOOT

a. **Definition/Characteristics.** Both trench foot and immersion foot result from prolonged exposure of the feet to wet cold. Trench foot results from exposing the foot to wet conditions in cold weather (50° to 32°F) for an extended period of time, usually over 12 hours. Immersion foot results from the foot being immersed in water--with or without socks and/or boots--for an extended period of time, the water temperature being 50°F or below. Both cold injuries are local, nonfreezing injuries manifested by vascular and superficial tissue changes. There are two classification stages: ischemic and hyperemia. In the ischemic stage, there is tissue anemia due to obstruction of the inflow of arterial blood. In the hyperemia stage, there is an excess of blood in a body part.

### b. Signs/Symptoms.

#### (1) Ischemic stage.

(a) **Feeling.** The person experiences coldness and wetness, often from the waist down. There is numbness and loss of sensation in the affected part. The feet are stiff and the person has a wooden feeling in the feet. Walking is difficult and painful.

(b) **Color/appearance.** The skin of the affected part is mottled with cyanotic (blue) splotches, and there is swelling.

(c) **Examination.** When the area of injury is examined by touch, there is no resilience and no pulse.

#### (2) Hyperemic stage.

(a) **Feeling.** The injured area is hot, and there is constant burning pain.

(b) **Color/appearance.** The skin of the area is red and swollen, and blisters and blebs commonly occur.

(c) **Examination.** When touched, the area feels woody and there is a bounding pulse.

(d) There is massive edema (fluid in the cells) and extravasation of blood (diffusing through the surrounding tissues).

(e) Gangrene, the death of tissue caused by lack of blood supply, may also occur.

**c. Treatment--Ischemic Stage.**

- (1) Gently wash, dry, and powder feet in a warm environment.
- (2) Lay or sit the victim down, elevate and expose the feet to cool air, keeping the rest of the body warm.
- (3) Do not massage, immerse in water, or attempt uncontrollable, rapid rewarming. Any of these will hasten the development of the hyperemic stage and subsequent formation of blisters, with the potential for the development of infection and subsequent gangrene.

**Section III. FREEZING COLD INJURY: FROSTBITE**

**5-7. DEFINITIONS/CHARACTERISTICS**

Frostbite results from crystallization of tissue water in the skin and adjacent tissues and is produced by exposure to temperatures below the freezing point. The depth and severity of the injury is a function of the temperature and the duration of exposure--the lower the temperature, the shorter the time required to produce injury. At low temperatures in the presence of wind, freezing of exposed skin can occur within a few seconds. Deep injury affects muscles, vessels, cartilages, and bones.

**5-8. PHYSIOLOGICAL ACTION**

In frostbite, there is tissue damage during freezing with possible damage during the thawing process. Changes in intracellular and extracellular biochemistry take place. Tissue dehydration occurs with local oxygen depletion and eventually disruption of the function of the blood corpuscles. Thrombosis (clotting within the small blood vessels) takes place and, if the condition is not relieved, eventually gangrene occurs.

**5-9. SIGNS/SYMPTOMS**

Frostbite is identified from the history of exposure to freezing temperature in addition to clinical signs and the appearance of an affected part of the body. Even severely frostbitten tissue may appear almost normal while still frozen.

- a. Before thawing, the affected area appears hard, white, and bloodless. The skin is rigid and the depth of freezing is difficult to determine. Sometimes a slight purplish discoloration and insensitivity to light touch are the only indications that a part of the body is frostbitten.



b. Patients describe the affected part as bulky or "clublike," implying numbness. The patient may also report that the part was very painful before it became numb. If the person was preoccupied at the time of freezing, he may not have felt any change until there was no feeling. If thawing has already occurred at the time the patient is seen, he may report that as the area warmed he felt throbbing, burning pain similar to a "pins and needles" sensation.

c. Blisters may not appear for a day or two after thawing or they may appear rapidly after thawing.

## **5-10. FROSTBITE MANAGEMENT/TREATMENT**

The basic management for frostbite is the same in principle for both superficial and deep frostbite, but the location of the treating (field, hospital) may put limits on what can be done. Management/treatment of frostbite should proceed as follows.

a. Obtain a careful history of the nature and length of time of exposure including the temperature, wind velocity, and clothing worn.

b. Examine the patient for other injuries such as fractures or dislocations.

c. Initiate appropriate treatment before frostbite therapy, if indicated.

d. Rewarm affected face, ears, cheeks, fingers, and toes with the body heat of one's own body or another person's body (abdomen, armpit, or groin).

e. Victims must be relieved of their duties long enough to rewarm in a warming tent.

f. The patient should be given warm drinks such as juice and warm gelatin. If possible, avoid all caffeine-containing liquids such as coffee, teas, and chocolate.

g. Smoking is prohibited.

h. Evacuate obviously deep frostbitten persons immediately. If this is not tactically possible, it is better to leave the area frozen than to allow refreezing after thawing.

i. DO NOT massage, rub, pack with ice or snow, cover with ointments, bandage lightly, or warm with uncontrolled heat sources (such as open fires or engine exhausts) any frostbite injury.

j. Carefully remove any clothing covering affected areas so as not to inflict further tissue damage. If the person is wearing gloves, boots, or socks that have been frozen on, proceed with rewarming and remove the clothing when it can be done without force.

- k. Treat the affected area.
  - (1) Submerge the affected area in a 5-10 gallon vessel of water at 100-110°F, initial temperature and maintain that temperature.
  - (2) Affected area should float freely without touching sides of the vessel.
  - (3) Circulate water manually or with whirlpool.
  - (4) Use a thermometer to monitor water temperature throughout the thawing process.
  - (5) Maintain water temperature above 100°F by alternately bailing out cooler water and adding hot to prevent additional tissue injury.
  - (6) Precautions.
    - (a) Temperatures higher than 110°F may add burns to the injury.
    - (b) Do not pour hot water directly on the extremity.
- l. Continue the process until the distal tips of the extremity are flushed (hyperemic); this may require 45 minutes.
- m. Monitor the patient's heart; be alert for arrhythmias if hypothermia accompanies the frostbite.
- n. When more than one extremity is involved, assign one person to each container to maintain the temperature and circulate the water.
- o. Once the tissue has thawed, handle the part gently and with sterile technique-advise the patient not to use the extremity.
- p. During the rewarming, aspirin provides sufficient analgesia for some patients; others require as much as 100 mg of meperidine hydrochloride (Demoral) or 15 mg of morphine sulfate in order to tolerate the treatment.
- q. Administer an antitetanus injection.
- r. Absolute bed rest for the patient in a warm area must be enforced following thawing.
- s. If the feet are involved, prescribe bed rest and a cradle to keep bed clothes off the injury.

t. Elevate frostbitten hands on pillows or with slings. Separate frozen digits with small wedges of cotton.

u. Avoid dressing, but loosely wrapped sterile towels are permissible to help protect the extremity.

v. After rapid rewarming, the mainstay of therapy is vigorous treatment.

(1) Use whirlpool baths in a solution to which an antiseptic such as povidone iodine (Betadine) or hexachlorophene has been added.

(2) Repeated whirlpool therapy of 20 to 30 minutes.

(3) Debride the injury two to three times daily to alleviate pain and help control infection.

w. While the patient is in the whirlpool, perform active, continuous complete range of motion physical therapy to prevent flexion contracture during the healing process.

## **Section IV. HYPOTHERMIA**

### **5-11. GENERAL PROCEDURES**

An individual suffering from a cold injury resulting in hypothermia has a body temperature which is lower than normal. The primary intent in treating this individual is to restore the core temperature of the body to normal levels. The means of rewarming the person can be divided into two broad categories: external or surface methods and internal or core methods. In external or surface methods, the body shell is warmed before the core of the body is warmed. In the second method--internal or core rewarming--the core of the body is warmed before the body shell.

### **5-12. EXTERNAL OR SURFACE REWARMING METHOD**

This method of rewarming may be accomplished actively by immersion in 40°C water, heating blankets, hot water bottles, or heat cradles.

a. The preferred method of active rewarming is to immerse the patient partially in warm water (40°C). Immerse just the torso, rigging a sling system to keep the head, legs, and arms out of the water. This may prevent some after drop in temperature. When frostbite of the feet or hands is a complication, you may immerse the whole body.

b. Note the following precautions.

(1) Monitor the casualty carefully. Once the rewarming has begun, rewarm his body evenly but not so rapidly as to shock his circulatory system. If the person is rewarmed too rapidly, the shock can cause cardiac arrhythmia or even cause the heart to stop beating altogether.

(2) If the casualty is conscious, give him something warm and nutritious to drink. Sugar or glucose tablets may be added to sweeten drinks. The heat from the drink can be absorbed by the body, and the sugar can be used by the body to produce heat. DO NOT give the person any alcoholic beverages to drink. Alcohol causes capillaries to dilate in turn causing the body to lose heat at a more rapid rate.

(3) Vital signs must be closely monitored, and continuous display of the electrocardiogram is essential since fatal arrhythmias may develop without warning.

(4) Hypokalemia (abnormally low potassium concentration in the blood) is commonly seen in hypothermia despite the usually associated acidosis, which is probably secondary to the intracellular migration of potassium and should not be interpreted as a compelling requirement for vigorous replacement. Therefore, avoid fluids that contain added potassium.

(5) Ringer's lactate solution or saline can be used for volume expansion.

### **5-13. INTERNAL OR CORE REWARMING METHOD**

This method of rewarming is preferred for patients whose temperature is under 90° to 92°F. Cardiopulmonary bypass and femoral A-V shunt are effective internal rewarming techniques but the heated peritoneal dialysis method is used most often. The process is as follows:

a. Heat regular potassium-free dialysate fluid to 110°F by running it through a blood warming coil immersed in a bucket of water at 130°F.

b. Run in two liters of fluid as rapidly as possible in about ten minutes. Then, immediately remove the fluid through the same trocar (an instrument used for withdrawing fluid from a body cavity). Usually six exchanges (12 liters) are sufficient.

### **5-14. CONCLUDING PROCEDURES**

a. During rewarming, continue respiratory support, correction of volume, and monitoring of temperature, ECG, blood pressure, blood gases, and electrolytes. Get repeat blood gases and electrolytes every 15 to 20 minutes for one hour, then as needed. Correct acidosis cautiously. Monitor the patient closely for 24 hours.

b. After rewarming the patient, obtain chest x-rays to check for pneumonia and skull x-rays to rule out heat injury. Pneumonia is the most common sequela (abnormal condition resulting from a previous disease) of hypothermia.

c. Unless other injuries require treatment, a person who has had mild hypothermia (over 92°F) can simply be rewarmed and returned to duty. Those individuals whose temperatures have been below 92°F should be monitored very closely for 24 hours. Most of these patients should remain hospitalized for three to five days after rewarming.

## **Section V. SENSITIZATION TO COLD INJURIES**

### **5-15. SENSITIZATION**

Frequently, in all degrees of cold injury, the affected individual becomes sensitized to further exposure to cold. With milder injuries, sensitization to cold may persist only days or weeks. In more severe injuries, cold sensitivity of the injured part may be permanent. Consequently, additional precautions must be taken by a person once injured by cold to prevent further injuries. In certain cases, true "cold sensitivity" or "allergy" may exist. Such persons may demonstrate urticaria or "hives" with intense burning, itching, and swelling when exposed to cold. Generally, this happens to persons who have had a cold injury. Rarely, however, this reaction may be a family trait or happen to a person who has plasma cryoglobulin or cold agglutinins. In such persons, cold exposure may cause a systemic reaction of generalized urticaria, asthma, and even shock.

### **5-16. WIND CHILL CHART**

a. Remember that the human body is continually producing and losing heat. Wind increases the loss of heat by reducing the thin layer of warm air next to the skin. This loss increases as the wind speed increases. When the temperature of the air is below freezing and the wind is such that it removes the heat faster than the body can produce it, frostbite may occur. Thus, decreasing the air temperature or increasing the wind speed act to increase the danger of cold injury (frostbite) to the skin. The combined effect of wind and temperature is expressed in the wind chill chart (table 5-1) as an equivalent temperature. This chart shows the effective temperature acting upon skin.

b. Any movement of air past the body has the same cooling effect as wind. This may be produced by walking, running, skiing, or riding in open vehicles. The speed of movement must be considered, in addition to natural wind, when you are using the windchill chart.

# WIND CHILL CHART

Temperature (°F)

		Calm	40	35	30	25	20	15	10	5	0	-5	-10	-15	-20	-25	-30	-35	-40	-45
Wind (mph)	5	36	31	25	19	13	7	1	-5	-11	-16	-22	-28	-34	-40	-46	-52	-57	-63	
	10	34	27	21	15	9	3	-4	-10	-16	-22	-28	-35	-41	-47	-53	-59	-66	-72	
	15	32	25	19	13	6	0	-7	-13	-19	-26	-32	-39	-45	-51	-58	-64	-71	-77	
	20	30	24	17	11	4	-2	-9	-15	-22	-29	-35	-42	-48	-55	-61	-68	-74	-81	
	25	29	23	16	9	3	-4	-11	-17	-24	-31	-37	-44	-51	-58	-64	-71	-78	-84	
	30	28	22	15	8	1	-5	-12	-19	-26	-33	-39	-46	-53	-60	-67	-73	-80	-87	
	35	28	21	14	7	0	-7	-14	-21	-27	-34	-41	-48	-55	-62	-69	-76	-82	-89	
	40	27	20	13	6	-1	-8	-15	-22	-29	-36	-43	-50	-57	-64	-71	-78	-84	-91	
	45	26	19	12	5	-2	-9	-16	-23	-30	-37	-44	-51	-58	-65	-72	-79	-86	-93	
	50	26	19	12	4	-3	-10	-17	-24	-31	-38	-45	-52	-60	-67	-74	-81	-88	-95	
	55	25	18	11	4	-3	-11	-18	-25	-32	-39	-46	-54	-61	-68	-75	-82	-89	-97	
	60	25	17	10	3	-4	-11	-19	-26	-33	-40	-48	-55	-62	-69	-76	-84	-91	-98	
	<b>FROSTBITE OCCURS IN:</b>										30 minutes			10 minutes			5 minutes			

$$\text{Wind Chill (°F)} = 35.74 + 0.6215T - 35.75(V^{0.16}) + 0.4275T(V^{0.16})$$

T = Air Temperature (°F)

V = Wind Speed (mph)

**NOTE:** Trench foot and immersion foot may occur at any point on this chart.

Table 5-1. Cooling power of wind on exposed flesh expressed as an equivalent temperature (under calm conditions). (Wind chill chart).

c. The wind chill chart can predict frostbite only to exposed flesh. Any clothing or material which stops or reduces the wind will give some protection to the covered area. Wet clothing or boots, however, do not have much insulating value and will result in heat loss nearly equal to that of exposed flesh.

d. To use the wind chill chart, locate the actual or estimated wind speed in the left hand column and the temperature of the air in degrees Fahrenheit across the top of the chart. Draw a line into the chart from each figure; the temperature with the windchill figured in is the point in the chart where those two lines cross (intersect). See figures 5-1 and 5-2 for examples.

Air temperature	-10° F
<u>Wind speed</u>	<u>calm</u>
Equivalent temperature	-10° F

No wind is making the air colder; therefore, the temperature of the air which touches exposed flesh is -10° F. According to the wind chill chart, the danger of frostbite to a properly clothed person is slight.

Figure 5-1. Example #1 of using the wind chill chart.

Air temperature	-10° F
<u>Wind speed</u>	<u>10 mph</u>
Equivalent temperature	-28° F

Note that if the wind speed increases to only ten miles per hour or if the individual is riding in an open vehicle which is being driven only ten miles per hour, the rate of heat loss to exposed flesh increases as if the temperature was -28°F with no wind. This lies within the zone of increasing danger from frostbite, indicating that the person must protect himself against exposure.

Figure 5-2. Example #2 of using the wind chill chart.

**Continue with Exercises**

## EXERCISES, LESSON 5

**INSTRUCTIONS.** The following exercises are to be answered by marking the response that best answers the question or best completes the incomplete statement or by writing the answer in the space provided.

After you have completed all the exercises, turn to the solutions at the end of the lesson and check your answers. For each exercise answered incorrectly, reread the material referenced after the solution.

1. Cold injury is \_\_\_\_\_.
2. There are two cold injuries which are the result of prolonged exposure of the feet to wet cold: \_\_\_\_\_ foot is cold in wet socks and boots; \_\_\_\_\_ is exposure of the feet to cold water--with or without boots.
3. \_\_\_\_\_ result from on-and-off-again exposure to temperatures above freezing with high humidity.
4. \_\_\_\_\_ is the result of tissue-water crystallizing in the skin and adjacent tissues and is caused when the person is exposed to temperatures that are below freezing.
5. List the three environmental factors which influence whether or not a person is liable to suffer a cold injury.
  - a. \_\_\_\_\_.
  - b. \_\_\_\_\_.
  - c. \_\_\_\_\_.
6. One way for a person to conserve body heat in cold weather is to wear loose layers of clothing with \_\_\_\_\_ between the layers.



7. List four important factors which relate to whether or not a person is a candidate for a cold injury.
  - a. \_\_\_\_\_.
  - b. \_\_\_\_\_.
  - c. \_\_\_\_\_.
  - d. \_\_\_\_\_.
  
8. A person has a cold injury and begins to shed skin at the injury site about eight days after the injury took place. That person probably has a \_\_\_\_\_ degree cold injury.
  
9. Twelve days after the incident of the cold injury, Soldier X began to feel an aching pain at the part of the body which had the injury. Soldier X is probably suffering from \_\_\_\_\_ degree cold injury.
  
10. Soldier W has edema of the foot (the foot being the part of the body suffering from a cold injury). This is a symptom of \_\_\_\_\_ degree cold injury.
  
11. A person can prevent cold injury to the body by conserving the total \_\_\_\_\_ heat, avoiding unnecessary prolonged exposure to \_\_\_\_\_, \_\_\_\_\_, and activities favoring cold injury.
  
12. List two duties of the Cold Injury Control Officer.
  - a. \_\_\_\_\_.
  - b. \_\_\_\_\_.

13. One way for soldiers to make and maintain their body heat is to do exercises involving the body's large muscle groups in the \_\_\_\_\_, \_\_\_\_\_, and legs.
14. A treatment for a person with chilblains in the hands is to \_\_\_\_\_  
\_\_\_\_\_.
15. A person is suffering from \_\_\_\_\_ if the injured part of the body before it is thawed appears hard, white, and bloodless.
16. To treat a person suffering from trench foot in the ischemic stage, you should include gently washing, \_\_\_\_\_, and \_\_\_\_\_ the person's feet in a warm environment.
17. A soldier being treated for frostbite should not be given liquids containing c\_\_\_\_\_ such as c\_\_\_\_\_, t\_\_\_\_\_, or c\_\_\_\_\_.
18. In the hospital, if the patient has frostbitten feet, bed rest and a \_\_\_\_\_ to keep the bed clothes off the injury will be prescribed.
19. A person suffering from a cold injury resulting in hypothermia has a body temperature which is \_\_\_\_\_.
20. The wind chill chart shows the \_\_\_\_\_ acting on a person's skin.

**Check Your Answers on Next Page**

## SOLUTIONS TO EXERCISES, LESSON 5

1. Tissue trauma produced by exposure to the cold. (para 5-1a)
2. Trench foot.  
Immersion foot. (para 5-1b)
3. Chilblains. (para 5-1d(1))
4. Frostbite. (para 5-1e(1))
5. Weather.  
Type of combat action.  
Clothing. (para 5-2b)
6. Air space. (para 5-2b(3)(a))
7. You are correct if you listed any four of the following:

Age.	Discipline.	Geographic origin.
Rank.	Training.	Nutrition.
Previous cold injury	Experience.	Activity.
Psychological factors	Drugs & medication.	Fatigue.
Alcohol.	Concomitant injury	Race.

(para 5-2c(1)-(13))
8. First. (para 5-3a(6))
9. Second. (para 5-3b(10))
10. Third. (para 5-3c(2))
11. Body.  
Cold, moisture. (para 5-4a)
12. You are correct if you listed any two of the following:

Observe soldiers frequently for signs/symptoms of cold injury.  
Be sure there is a daily check of soldiers for good personal hygiene, including an effort to keep feet clean and dry.  
Encourage soldiers to exercise and avoid tight clothing and footgear.  
(para 5-4c)
13. Shoulders, trunk. (para 5-4f(4))

14. Warm the patient's hands. (para 5-5e)
15. Frostbite. (para 5-9a)
16. Drying, and powdering. (para 5-6c(1))
17. Caffeine.  
Coffee, tea or chocolate. (para 5-10f)
18. Cradle. (para 5-10s)
19. Lower than normal. (para 5-11)
20. Effective temperature. (para 5-16a)

**End of Lesson 5**